

**BizLink**

*Dresspacks &  
Integration-Ready Robots*  
**管线包与集成的机器人**

工厂自动化  
Factory Automation



## 我们的机器人解决方案



GB



CN

A reliable power supply is essential to every industrial process. This is because all production will generally grind to a halt if particular signals cannot be transmitted or required media cannot be supplied. Our many years of experience in industry mean we can deal with even the most difficult circumstances. We supply, assemble and install standard dresspacks – whether on robots or on special machines. We secure a long service life and thus a smooth and resource-conserving production process.

In the following, we illustrate diverse examples of robotic applications. There are no limits to the variety of dresspacks and mounted parts. Blue corrugated hoses or yellow smooth tube systems, overhead or special installations for special machinery – we provide you with the best solutions for every application and every robot type.

一个可靠的电气连接对于每个工业过程来说都是必不可少的。这是因为如果特定的信号不能传输或不能提供必需的媒介，通常将导致所有生产都会停顿下来。我们在工业领域拥有多年的经验，这意味着我们甚至可以应对最困难的情况。我们提供、装配和安装标准管线包——无论是用于机器人或其他专业机器。我们确保产品具有较长的使用寿命，从而保证生产流程顺利进行并节约资源。

在下文中，我们将列举出各种机器人的应用范例。管线包和组件的种类无限。蓝色波纹管或黄色光滑套管系统，可针对倒装的机器人或用其他特殊方式安装的机器人——我们都将向您提供每种应用和每款机器人的最佳解决方案。

	page
<b>Dresspack systems / 管线包系统</b>	<b>4</b>
Overview / 目录	5
• LSH 3	6
• LSC	7
• B-Flex	8
• Special solutions / 特殊解决方案	8
Complete system examples / 整套系统示例	9
<b>Assemblies &amp; components / 组件与零件</b>	<b>30</b>
Assemblies / 组件	31
Components for corrugated hoses / 波纹管组件	34
Accessories / 配件	46
Components for smooth tube systems / 光滑配管组件	47
Components for light weight and collaborative robots / 轻型及协作型机器人组件	51
Connectors & contacts for spot welding / 点焊连接器与端子	52
Special components & tools / 特殊零件与工具	53
<b>Integration-ready robots / 集成的机器人</b>	<b>54</b>
Scope of supply / 供应范围	58
<b>Dresspack services / 管线包服务</b>	<b>59</b>
Installation / 安装	60
Optimization of dresspack systems and trajectories / 管线包系统与轨迹的优化	61
Final check / 最终检查	62
Maintenance "management" service / "管家式"保养服务	63
Repair and refurbishment of dresspack systems / 管线包系统的维修与翻新	64
Training / 培训	64
Conversion / 换算	65
Factory Automation / 工厂自动化	66
About BizLink Group	68
关于贸联	69
Sales network / 销售网络	70
Your contact / 联系方式	71



## Dresspack systems 管线包系统

There are no limits to the variety of dresspacks and components. Blue corrugated hoses or yellow smooth tube systems, upside down or special installations for special machinery.

**We provide you with  
the suitable solution** >  
for every application  
for every robot type

管线包和组件的种类无限。蓝色波纹管或黄色光滑套管系统，可针对特殊机械倒置或用其他特殊方式安装。

**我们根据您的需求提供合适的  
解决方案** >  
适合任何应用  
适合任何机器人类型

## Overview 概览





## LSH 3

Reliable, compact and flexible, the LSH 3 is the most innovative dresspack solution in the global market today. Its intelligent and extremely compact design minimise one of the most common causes of error for robot power supply – collision with interfering contours. This benefit in combination with extremely durable materials and proven components creates maximum clearance with a close-fitting dresspack on the robot arm.

### The LSH 3's benefits include >

- **Compact design: fewer interfering contours and lower risk of collision**
- **Significantly reduced volume, overall weight and length**
- **Maximum flexibility for dresspack routing**
- **Compatibility with all LSH versions, without the need for any additional programming**
- **Compatible to corrugated and smooth yellow tube umbilicals**
- **Significantly faster replacement of dresspacks in comparison with earlier models**
- **No maintenance on the retraction element required**
- **All components are subjected to extensive field testing**

LSH 3 is available for new robots, regardless of size, manufacturer, type or application, as well as retrofits and upgrades for existing workcells. It can be mounted vertically, horizontally or upside down and each system can accommodate up to two dresspacks with the widest range of nominal diameters. Optionally, a rotating pivot bearing can be mounted on the front end, which supports even the most extreme movement sequences while reducing stress on the dresspack. The standard extension length of the LSH 3 is 350 mm. Mounting can take place on a customer-specific basis on axis 3, with or without adapter plate. Do you have special requirements? We would be glad to write up an individual offer for you.

### Your LSH 3 – your individual design

Let us know if you would like your LSH 3 housing in a custom colour or provided with your company logo. We can also provide the LSH 3 with custom extension lengths after prior arrangement.

贸联全新设计的LSH 3 是全球市场上最具创新的管线包解决方案, 它更可靠、更紧凑、更灵巧。LSH 3 以其超紧凑和精巧的设计最大程度地减少了机器人管线包最常见的问题——与运动轨迹干涉点的碰撞。这得益于采用极其耐用的材料和可靠的组件, 为与机器人手臂紧贴的管线包创造出了最大空间。

### LSH 3 优势如下 >

- **紧凑型设计: 更少的干扰轮廓、更低的碰撞风险**
- **体积、总重量和长度明显减少**
- **最大化管线包运动轨迹的灵活性**
- **兼容所有LSH 版本, 无需对现有轨迹重新示教**
- **与波纹管线包/黄色光滑管线包兼容**
- **与早期型号相比, 管线包的更换速度明显更快**
- **回缩机构无需维护**
- **铝防护罩**
- **对2轴或3轴接口板应用方案都适用**
- **所有组件均进行了大量的现场测试**
- **全球专利保护**

LSH 3 可适用于新型机器人, 不受尺寸、制造商、型号或者应用影响, 也可用于现有车间的改造升级。可以垂直或水平安装, 且每个系统可以容纳多个最大公称直径范围内的管线包。另外, 在系统的前端可以选择安装一个可旋转的机构, 不仅帮助完成超级复杂的运动顺序, 同时还能减轻管线包压力。LSH 3 的标准伸缩行程为350 mm。如果您有特殊需求, 我们很乐意为您提供个性化产品。

### LSH 3 – 您的专属设计

如果您想让 LSH 3 壳体拥有自己喜欢的颜色或图标, 请告诉我们。甚至是特殊长度伸缩行程的 LSH 3, 我们也乐意为您提供。

## LSC

The LSC can be used in dirty surroundings like e.g. in sandblasting or milling applications.

LSC 可用于较脏的环境, 如喷砂或铣削应用。

The system is easy to clean without opening it. The LSC is applicable for different nominal widths (48, 70 & 95). All other widths can be adapted, accordingly. It is predestined to be used for applications with maximum bending radius or straight feeding applications e.g. for rivets or studs.

该系统易于清洁, 无需打开。LSC适用于不同的标称宽度 (48、70、95), 可以进行相应的调节以适应所有其他的宽度。它特别适合用于具有最大弯曲半径或直接进料的应用, 如铆钉或螺栓。

Generally, several systems can be installed compactly and in parallel on the robot e.g. leading several dresspacks to the robot tool.

通常, 可以将多个系统紧凑而平行地安装在机器人上, 如将多个管线包引导至机器人工具。



## B-Flex



BizLink's expertise in designing cable management systems for traditional industrial robots now extends to lightweight and collaborative robots with the recent introduction of the BizLink B-Flex cable management system.

The flexible, anti-slip BizLink B-Flex can be installed on any type of robot arm and on surfaces such as aluminum, varnish, and cast iron. Its adjustable straps ease installation; there's no need for tools, screw connections, or modifications to the robot. Application on various diameters of the robot arm is simple thanks to the BizLink B-Flex's ideal bending properties and flexibility of the cable mounting brackets. It reduces the chance of robots colliding with interfering contours, such as sharp edges and metal parts, keeping workers safe. The adjustable brackets also simplify maintenance and repairs. All BizLink cable management systems go through an extensive testing process to ensure functionality before installation at your facility or line builder. BizLink continues to support you by offering on-site installation, optimization, and repair. After-sale services are available through individual service calls or preventive maintenance contracts.

BizLink 贸联将其在传统工业机器人电缆管理系统方面的专业知识拓展至轻型及协作型机器人, 并于近期推出 BizLink B-Flex 电缆管理系统。

灵活、防滑的 BizLink B-Flex 可以安装在任何类型的机器人手臂以及铝、清漆和铸铁等表面上。可调节魔术贴方便安装; 无需工具、螺钉连接或对机器人进行修改。得益于 BizLink B-Flex 理想的弯曲性能和电缆安装支架的灵活性, 在各种直径的机器人手臂上的安装都很简单。它减少了机器人与干扰轮廓 (例如锋利边缘和金属部件) 碰撞的机会, 从而保证了工人的安全。可调节支架还简化了维护和修理。所有 BizLink 电缆管理系统都经过广泛的测试过程, 以确保在您的工厂或系统集成商安装之前功能正常。BizLink 提供现场安装、优化和维修等服务。可通过服务电话或预防性维护合同获取售后服务。

## Special solutions | 特殊应用



Aside from our standardized solutions we offer customized special solutions. The spring foot solution can be applied if no or only a small retract length is required and if the robot trajectory is simple. The open spring return system can be modified on site – **fast and simple**.

除标准解决方案外, 我们还提供定制的特殊解决方案。如果不需要或仅需较小的回缩长度且机器人轨迹简单, 则可以应用弹簧脚解决方案。开放式弹簧复位系统可以在现场进行修改——快速而简单。

Complete system examples  
整套系统示例

Pos.	Exemplary robot 典型机器人	Description 描述	Article no. 订购号
1	ABB IRB7600 340/2.8 ABB IRB7600 150/3.5 ABB IRB7600 400/2.55 ABB IRB7600 500/2.55	Complete system support BizLink dresspack LSH 3, axis 1-6, corrugated hose Ø 48/70 mm, e.g. handling BizLink LSH 3 整套管线包系统, 轴 1-6, 波纹管 Ø48/70 mm, 如搬运	DPS0083
2	ABB IRB7600	Complete system support BizLink dresspack LSH 3, axis 1-6, corrugated hose Ø 70 mm, e.g. welding or handling BizLink LSH 3 整套管线包系统, 轴 1-6, 波纹管 Ø70 mm, 如焊接或搬运	DPS0084



Pos.	Exemplary robot 典型机器人	Description 描述	Article no. 订购号
1	ABB IRB7600-340/2.80, -500/2.55	Complete system support BizLink dresspack LSH 3, axis 1-6, corrugated hose Ø 48/70 mm, e.g. handling BizLink LSH 3 整套管线包系统, 轴 1-6, 波纹管 Ø48/70 mm, 如搬运	DPS0030
2	ABB IRB6700-150/3.2/ -6640, IRB6700- 235-265c	Complete system support BizLink dresspack LSH 3, axis 1-6, corrugated hose Ø 70 mm, e.g. welding or handling BizLink LSH 3 整套管线包系统, 轴 1-6, 波纹管 Ø70 mm, 如焊接或搬运	DPS0031

**Note** ▶ Please contact us for your personal offer regarding empty dresspacks: [factory-automation.bizlinktech.com/contact/](http://factory-automation.bizlinktech.com/contact/)  
**备注** ▶ 联系我们获取空管线包的独立报价: [factory-automation.bizlinktech.com/zh/联系我们/](http://factory-automation.bizlinktech.com/zh/联系我们/)





Pos.	Exemplary robot 典型机器人	Description 描述	Article no. 订购号
1	ABB IRB6700 245/3.00, 300/2.70, 200/2.60, 235/2.65	Complete system support BizLink dresspack LSH 3, axis 1-6, corrugated hose Ø 70 mm, e.g. punching rivets or flow drilling BizLink LSH 3 整套管线包系统, 轴 1-6, 波纹管 Ø70 mm, 如冲孔铆钉或流钻	DPS0032
2	ABB IRB6700 245/3.00, 200/2.60, 235/2.65, 300/2.70	Complete system support BizLink dresspack LSH 3, axis 1-6, corrugated hose Ø 70 mm, parallel guidance, e.g. punching rivets or flow drilling BizLink LSH 3 整套管线包系统, 轴 1-6, 波纹管 Ø70 mm, 平行引导, 如冲孔铆钉或流钻	DPS0033

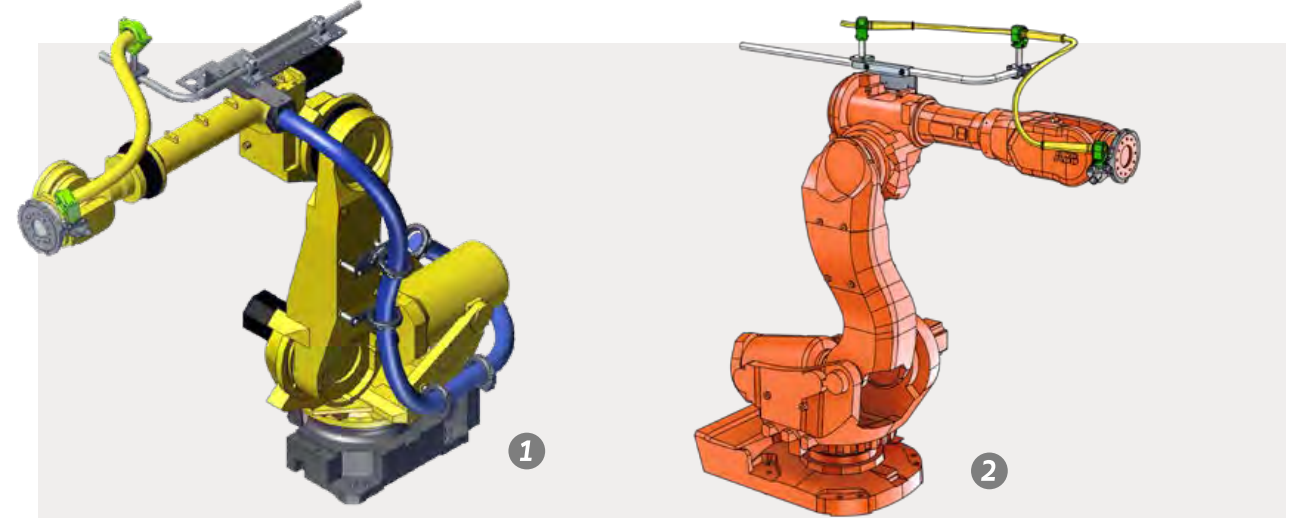

Pos.	Exemplary robot 典型机器人	Description 描述	Article no. 订购号
1	ABB 6600	System support yellow smooth tube system, axis 3-6, e.g. welding 黄色光滑配管系统, 轴 3-6, 如焊接	DPS0004
2	ABB 6600	System support yellow smooth tube system, axis 3-6, e.g. handling 黄色光滑配管系统, 轴 3-6, 如搬运	DPS0005



Pos.	Exemplary robot 典型机器人	Description 描述	Article no. 订购号
1	ABB IRB6700 245/3.00, 300/2.70, 200/2.60, 235/2.65	Complete system support BizLink dresspack LSH 3, axis 1-6, corrugated hose Ø 48/70 mm, e.g. glueing with double dosing unit (with 2 heating tubes) BizLink LSH 3 整套管线包系统, 轴 1-6, 波纹管 Ø48/70 mm, 如双剂量涂胶 (带两个加热管)	DPS0034
2	ABB 6600	Cantilever solution, axis 3-6 悬臂解决方案, 轴 3-6	DPS0003

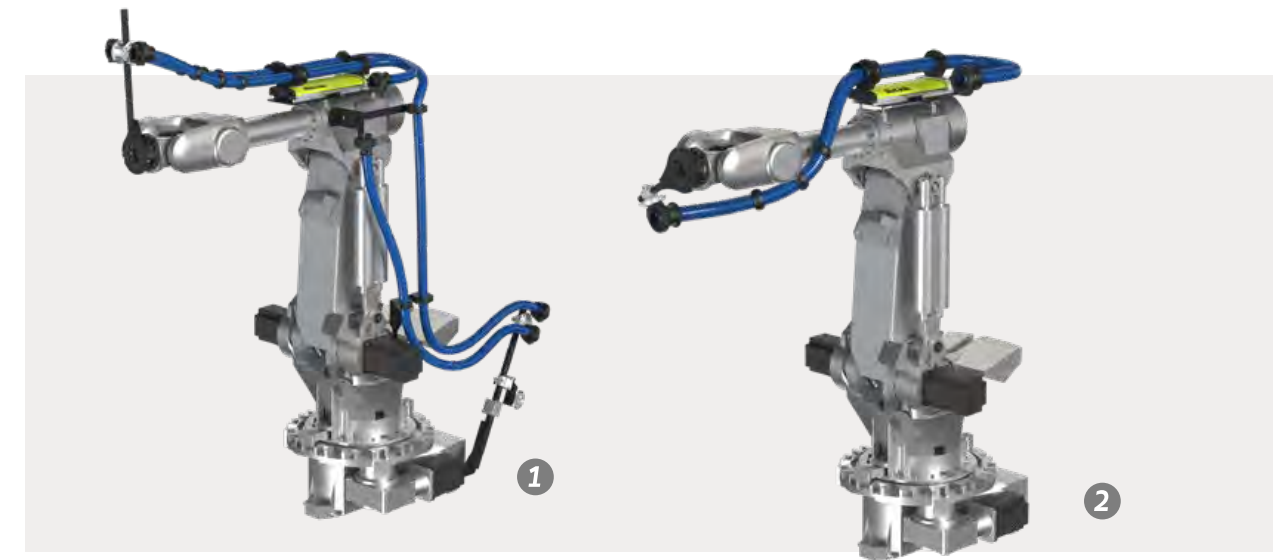

Pos.	Exemplary robot 典型机器人	Description 描述	Article no. 订购号
1	COMAU SMART H1	Complete system support BizLink dresspack LSH 3, axis HIP-6, corrugated hose Ø 48 mm, e.g. riveting, flow drilling, glueing BizLink LSH 3 整套管线包系统, 轴 HIP-6, 波纹管 Ø48 mm, 如铆接、流钻、涂胶	DPS0035
2	COMAU SMART H2	Complete system support BizLink dresspack LSH 3, axis 3-6, corrugated hose Ø 70 mm, e.g. welding or handling BizLink LSH 3 整套管线包系统, 轴 3-6, 波纹管 Ø70 mm, 如焊接或搬运	DPS0036

**Note** > Please contact us for your personal offer regarding empty dresspacks: [factory-automation.bizlinktech.com/contact/](http://factory-automation.bizlinktech.com/contact/)  
备注 > 联系我们获取空管线包的独立报价: [factory-automation.bizlinktech.com/zh/联系我们/](http://factory-automation.bizlinktech.com/zh/联系我们/)

**Note** > Please contact us for your personal offer regarding empty dresspacks: [factory-automation.bizlinktech.com/contact/](http://factory-automation.bizlinktech.com/contact/)  
备注 > 联系我们获取空管线包的独立报价: [factory-automation.bizlinktech.com/zh/联系我们/](http://factory-automation.bizlinktech.com/zh/联系我们/)

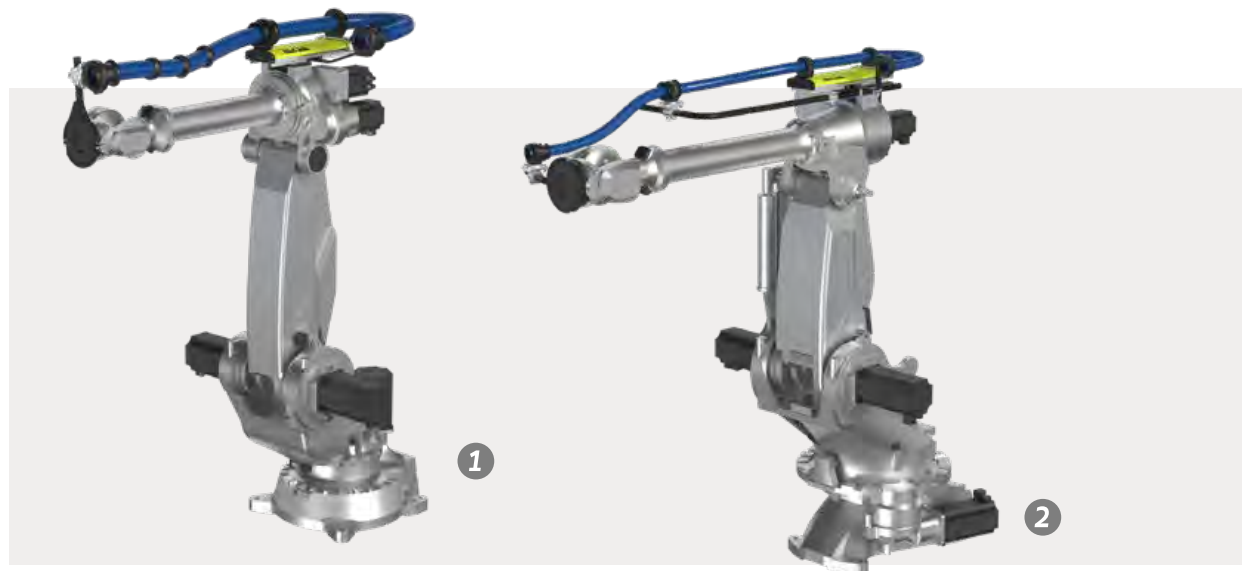

Pos.	Exemplary robot 典型机器人	Description 描述	Article no. 订购号
1	COMAU NJ 220-2.7	Complete system support BizLink dresspack LSH 3, axis 3 – 6, corrugated hose Ø 70 mm, e.g. welding or handling BizLink LSH 3 整套管线包系统, 轴 3–6, 波纹管 Ø70 mm, 如焊接或搬运	DPS0037
2	COMAU NJ370-2.7, NJ450-2.7, NJ500-2.7	Complete system support BizLink dresspack LSH 3, axis 3 – 6, corrugated hose Ø 48 mm, e.g. inline measurement or handling BizLink LSH 3 整套管线包系统, 轴 3–6, 波纹管 Ø48 mm, 如在线测量或搬运	DPS0038



Exemplary robot 典型机器人	Description 描述	Article no. 订购号
CHERY	Complete system support, axis 1– 6, e.g. welding or handling 整套管线包系统, 轴 1–6, 如焊接或搬运	DPS0006

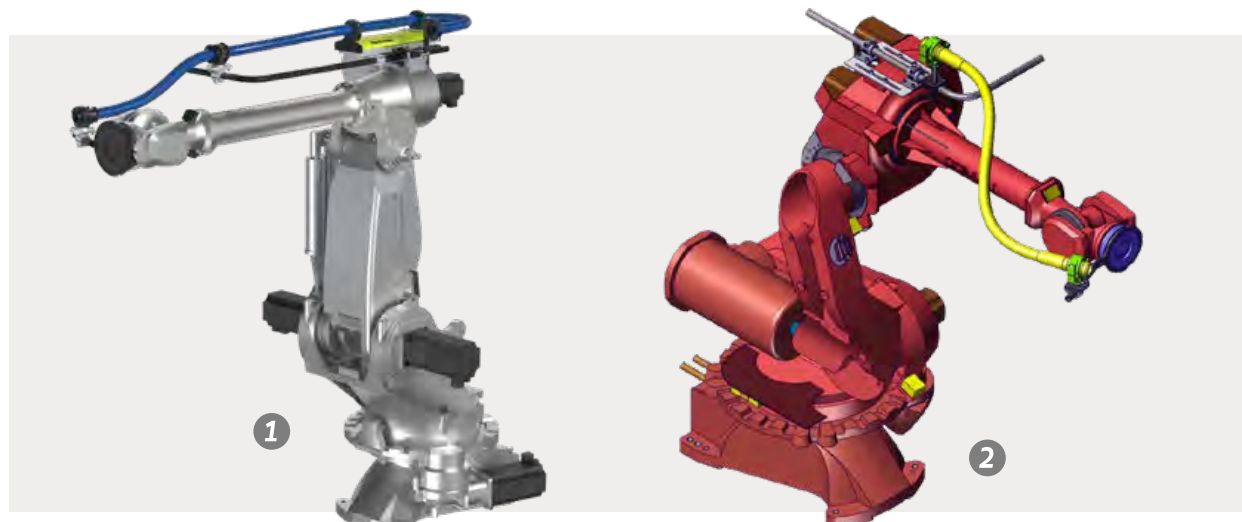

Pos.	Exemplary robot 典型机器人	Description 描述	Article no. 订购号
1	COMAU NJ290-3.0	Complete system support BizLink dresspack LSH 3, axis 3 – 6, corrugated hose Ø 48 mm, e.g. handling BizLink LSH 3 整套管线包系统, 轴 3–6, 波纹管 Ø48 mm, 如搬运	DPS0039
2	COMAU NH2-NH3	System support for yellow smooth tube system, axis 3 – 6, e.g. welding 黄色光滑配管系统, 轴 3–6, 如焊接	DPS0010



Exemplary robot 典型机器人	Description 描述	Article no. 订购号
Denso	Complete system support BizLink dresspack, axis 1 – 6, e.g. handling 整套管线包系统, 轴 1–6, 如搬运	DPS0040

**Note** ▶ Please contact us for your personal offer regarding empty dresspacks: [factory-automation.bizlinktech.com/contact/](http://factory-automation.bizlinktech.com/contact/)  
备注 ▶ 联系我们获取空管线包的独立报价: [factory-automation.bizlinktech.com/zh/联系我们/](http://factory-automation.bizlinktech.com/zh/联系我们/)

**Note** ▶ Please contact us for your personal offer regarding empty dresspacks: [factory-automation.bizlinktech.com/contact/](http://factory-automation.bizlinktech.com/contact/)  
备注 ▶ 联系我们获取空管线包的独立报价: [factory-automation.bizlinktech.com/zh/联系我们/](http://factory-automation.bizlinktech.com/zh/联系我们/)





Pos.	Exemplary robot 典型机器人	Description 描述	Article no. 订购号
1	FANUC R2000iB / -210F, -250F	Complete system support BizLink dresspack LSH 3, axis 2-6, corrugated hose Ø 48 mm, Parallel guidance, e.g. glueing BizLink LSH 3 整套管线包系统, 轴 2-6, 波纹管 Ø48 mm, 平行引导, 如涂胶	DPS0041
2	FANUC R2000iC 210L / 270F	Complete system support BizLink dresspack LSH 3, axis HIP-6, corrugated hose Ø 48/70 mm and slitted Ø 29 mm, Parallel guidance, e.g. laser BizLink LSH 3 整套管线包系统, 轴 HIP-6, 波纹管 Ø48/70 mm, 开槽 Ø29 mm, 平行引导, 如激光	DPS0042



Pos.	Exemplary robot 典型机器人	Description 描述	Article no. 订购号
1	FANUC R2000/ 210F-250F	Complete system support BizLink dresspack LSC and SLS, axis 1-6, corrugated hose Ø 48/70 mm, e.g. glueing BizLink LSC, SLS 整套管线包系统, 轴 1-6, 波纹管 Ø48/70 mm, 如涂胶	DPS0043
2	FANUC R2000iB-210F	Complete system support BizLink dresspack LSH 3, axis 1-6, corrugated hose Ø 48/70 mm, e.g. inline measurement BizLink LSH 3 整套管线包系统, 轴 1-6, 波纹管 Ø48/70 mm, 如在线测量	DPS0044

**Note** > Please contact us for your personal offer regarding empty dresspacks: [factory-automation.bizlinktech.com/contact/](http://factory-automation.bizlinktech.com/contact/)  
备注 > 联系我们获取空管线包的独立报价: [factory-automation.bizlinktech.com/zh/联系我们/](http://factory-automation.bizlinktech.com/zh/联系我们/)



Pos.	Exemplary robot 典型机器人	Description 描述	Article no. 订购号
1	FANUC R2000iC/ 125L	Complete system support BizLink dresspack LSH 3, axis 1-6, corrugated hose Ø 70 mm, e.g. handling BizLink LSH 3 整套管线包系统, 轴 1-6, 波纹管 Ø70 mm, 如搬运	DPS0045
2	FANUC R2000iC-165F /-210F	Complete system support BizLink dresspack LSH 3, axis 1-6, corrugated hose Ø 48/70 mm, e.g. handling BizLink LSH 3 整套管线包系统, 轴 1-6, 波纹管 Ø48/70 mm, 如搬运	DPS0046

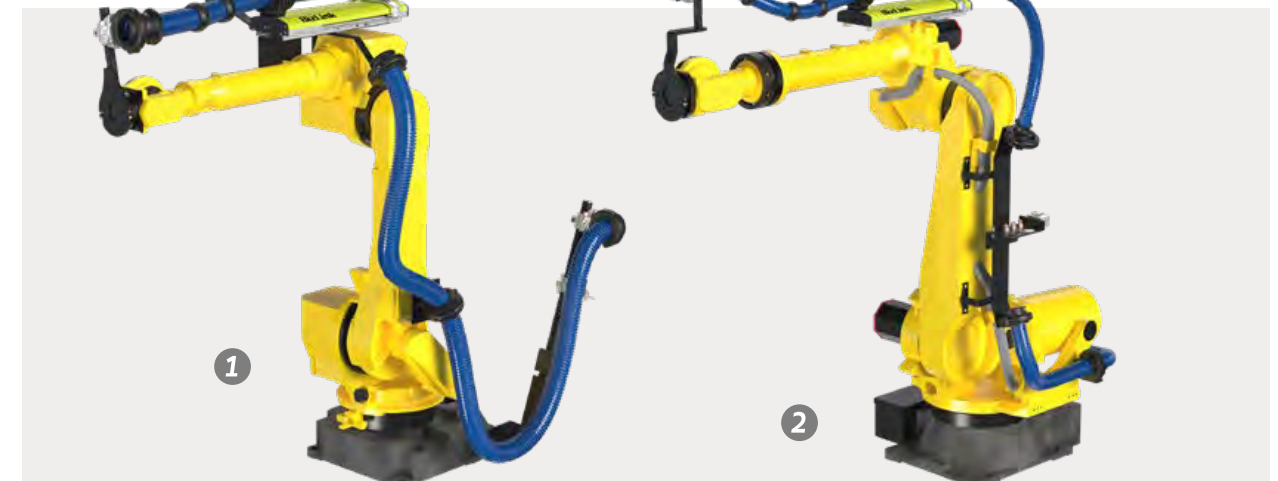

Pos.	Exemplary robot 典型机器人	Description 描述	Article no. 订购号
1	FANUC M710iC-50/70	Complete system support BizLink dresspack LSH 3, axis 1-6, corrugated hose Ø 48/70 mm, e.g. welding BizLink LSH 3 整套管线包系统, 轴 1-6, 波纹管 Ø48/70 mm, 如焊接	DPS0047
2	FANUC R2000iC -165F/ -210F/ -210R	Complete system support BizLink dresspack LSH 3, axis 1-6, corrugated hose Ø 48/70 mm, e.g. welding BizLink LSH 3 整套管线包系统, 轴 1-6, 波纹管 Ø48/70 mm, 如焊接	DPS0048

**Note** > Please contact us for your personal offer regarding empty dresspacks: [factory-automation.bizlinktech.com/contact/](http://factory-automation.bizlinktech.com/contact/)  
备注 > 联系我们获取空管线包的独立报价: [factory-automation.bizlinktech.com/zh/联系我们/](http://factory-automation.bizlinktech.com/zh/联系我们/)





Pos.	Exemplary robot 典型机器人	Description 描述	Article no. 订购号
1	FANUC R2000iC-270F	Complete system support BizLink dresspack LSH 3, axis 1-6, corrugated hose Ø 48 mm, e.g. handling BizLink LSH 3 整套管线包系统, 轴 1-6, 波纹管 Ø48 mm, 如搬运	DPS0049
2	FANUC R2000iC-270F	Complete system support BizLink dresspack LSH 3, axis 1-6, corrugated hose Ø 70 mm, e.g. welding or handling BizLink LSH 3 整套管线包系统, 轴 1-6, 波纹管 Ø70 mm, 如焊接或搬运	DPS0050

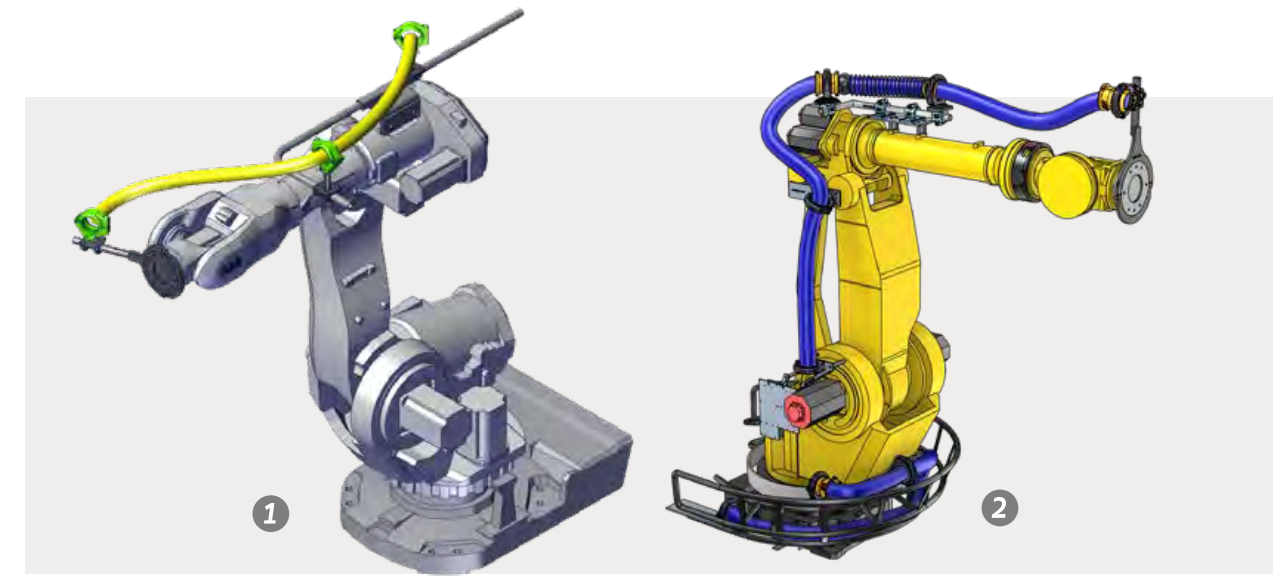

Pos.	Exemplary robot 典型机器人	Description 描述	Article no. 订购号
1	FANUC R2000iB	System overview for yellow smooth tube system axis 3-6 and corrugated dresspack axis 1-3, e.g. welding 黄色光滑配管系统, 轴 1-3, 如焊接	DPS0014
2	FANUC M900/ 350kg	Open spring return system, axis 1-2 and axis 2-6, e.g. welding or handling 开放式弹簧复位系统, 轴 1-2 及 轴2-6, 如焊接或搬运	DPS0015



Exemplary robot 典型机器人	Description 描述	Article no. 订购号
FANUC R2000iC-270F	Complete system support BizLink dresspack LSH 3, axis 1-6, corrugated hose Ø 70 mm, e.g. welding or handling BizLink LSH 3 整套管线包系统, 轴 1-6, 波纹管 Ø70 mm, 如焊接或搬运	DPS0051

**Note** > Please contact us for your personal offer regarding empty dresspacks: [factory-automation.bizlinktech.com/contact/](http://factory-automation.bizlinktech.com/contact/)  
**备注** > 联系我们获取空管线包的独立报价: [factory-automation.bizlinktech.com/zh/联系我们/](http://factory-automation.bizlinktech.com/zh/联系我们/)

**Note** > Please contact us for your personal offer regarding empty dresspacks: [factory-automation.bizlinktech.com/contact/](http://factory-automation.bizlinktech.com/contact/)  
**备注** > 联系我们获取空管线包的独立报价: [factory-automation.bizlinktech.com/zh/联系我们/](http://factory-automation.bizlinktech.com/zh/联系我们/)



Exemplary robot 典型机器人	Description 描述	Article no. 订购号
HYUNDAI HS200	Complete system support BizLink dresspack LSH 3, axis 1-6, corrugated hose Ø 70 mm, e.g. welding or handling BizLink LSH 3 整套管线包系统, 轴 1-6, 波纹管 Ø70 mm, 如焊接或搬运	DPS0052



Pos.	Exemplary robot 典型机器人	Description 描述	Article no. 订购号
1	KAWASAKI ZX200S	Complete system support BizLink dresspack LSH 3, axis 3-6, e.g. welding or handling BizLink LSH 3 整套管线包系统, 轴 3-6, 如焊接或搬运	DPS0053
2	KAWASAKI MX700N	Complete system support BizLink dresspack LSH 3, axis 1-6, with basket, e.g. clinching BizLink LSH 3 整套管线包系统, 轴 1-6, 带围栏, 如咬合	DPS0054

**Note** ▶ Please contact us for your personal offer regarding empty dresspacks: [factory-automation.bizlinktech.com/contact/](http://factory-automation.bizlinktech.com/contact/)  
备注 ▶ 联系我们获取空管线包的独立报价: [factory-automation.bizlinktech.com/zh/联系我们/](http://factory-automation.bizlinktech.com/zh/联系我们/)

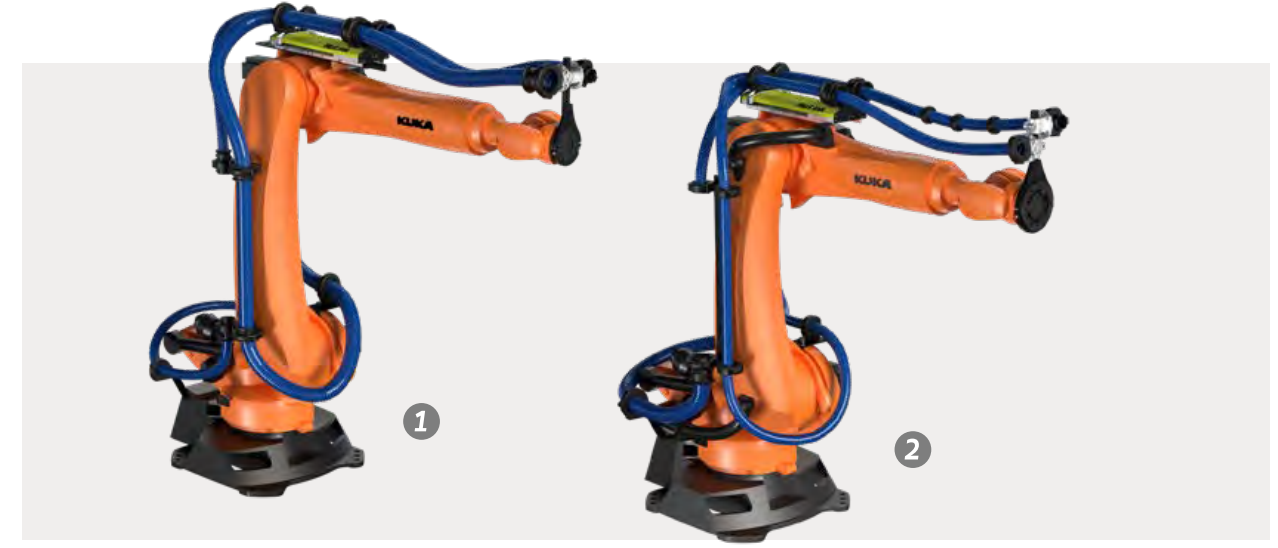

Pos.	Exemplary robot 典型机器人	Description 描述	Article no. 订购号
1	KUKA Quantec series 2010	Complete system support BizLink dresspack LSH 3, axis HIP-6 & axis 1-6, corrugated hose Ø 48/70 mm, e.g. glueing, riveting or flow drilling BizLink LSH 3 整套管线包系统, 轴 HIP-6 及轴 1-6, 波纹管 Ø48/70 mm, 如涂胶、铆接或流钻	DPS0055
2	KUKA Quantec series 2010	Complete system support BizLink dresspack LSH 3, axis HIP-6 & axis 1-6, corrugated hose Ø 48 mm, parallel guidance, e.g. glueing BizLink LSH 3 整套管线包系统, 轴 HIP-6 及轴 1-6, 波纹管 Ø48 mm, 平行引导, 如涂胶	DPS0056



Pos.	Exemplary robot 典型机器人	Description 描述	Article no. 订购号
1	KUKA Quantec KR210 R2700 extra,	Complete system support BizLink LSC, axis 1-6, corrugated hose Ø 48/70 mm, laser gun (e.g. IPG) BizLink LSC 整套管线包系统, 轴 1-6, 波纹管 Ø48/70 mm, 激光枪 (如IPG)	DPS0057
2	KUKA KR240 R3100 ultra, KR210 R2700 prime	Complete system support BizLink LSC, axis 1-6, corrugated hose Ø 70 mm, laser gun (e.g. IPG) BizLink LSC 整套管线包系统, 轴 1-6, 波纹管 Ø70 mm, 激光枪 (如IPG)	DPS0058

**Note** ▶ Please contact us for your personal offer regarding empty dresspacks: [factory-automation.bizlinktech.com/contact/](http://factory-automation.bizlinktech.com/contact/)  
备注 ▶ 联系我们获取空管线包的独立报价: [factory-automation.bizlinktech.com/zh/联系我们/](http://factory-automation.bizlinktech.com/zh/联系我们/)





Pos.	Exemplary robot 典型机器人	Description 描述	Article no. 订购号
1	KUKA Quantec Series 2010-R3100	Complete system support BizLink dresspack LSH 3, axis 1-6, corrugated hose Ø 48/70 mm, e.g. handling, stud welding BizLink LSH 3 整套管线包系统, 轴 1-6, 波纹管 Ø48/70 mm, 如搬运、螺柱焊	DPS0059
2	KUKA KR360-3 R2826	Complete system support BizLink dresspack LSH 3, axis HIP-6, corrugated hose Ø 70 mm, resistance spot welding, flow drill screwing, clinching, hollow riveting BizLink LSH 3 整套管线包系统, 轴 HIP-6, 波纹管 Ø70 mm, 电阻点焊、热熔钻拧紧、铆接、空心铆接	DPS0060



Pos.	Exemplary robot 典型机器人	Description 描述	Article no. 订购号
1	KUKA series 2010, Quantec	Complete system support BizLink dresspack LSH 3, axis 1-6, corrugated hose Ø 48 mm, Parallel guidance, e.g. glueing BizLink LSH 3 整套管线包系统, 轴 1-6, 波纹管 Ø48 mm, 平行引导, 如涂胶	DPS0063
2	KUKA KR360/500-1, KR360/500-2, KR360/500-3, KUKA KR500 L480-3 MTF	Complete system support BizLink LSC, axis 3-6, corrugated hose Ø 70 mm, e.g. handling with valve terminals at axis 3 (not illustrated) BizLink LSC 整套管线包系统, 轴 3-6, 波纹管 Ø70 mm, 如搬运配置与3轴气阀连接 (无图示)	DPS0064

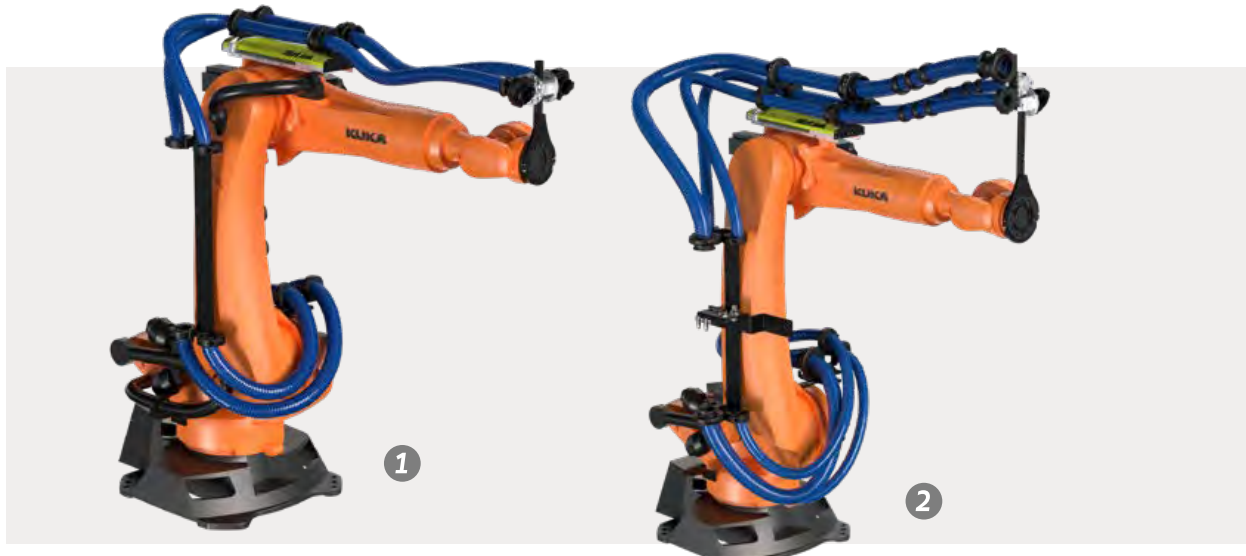

Pos.	Exemplary robot 典型机器人	Description 描述	Article no. 订购号
1	KUKA Quantec Series 2010	Complete system support BizLink LSH 3, axis HIP-6, corrugated hose Ø 48 mm, e.g. handling, vision BizLink LSH 3 整套管线包系统, 轴 HIP-6, 波纹管 Ø48 mm, 如搬运、视觉	DPS0061
2	KUKA KR 240 R2900 ultra, also series 2010	Complete system support BizLink dresspack LSH 3, axis 1-6, Corrugated hose Ø 70 mm, e.g. heating tubes with glue guns BizLink LSH 3 整套管线包系统, 轴 1-6, 波纹管 Ø70 mm, 如带胶枪的管子加热	DPS0062



Pos.	Exemplary robot 典型机器人	Description 描述	Article no. 订购号
1	KUKA 2010 90-210KG, 90-150-R3100, 210-300KG, 210KG-R3100 Quantec	Complete system support BizLink dresspack LSH 3, axis 1-6, corrugated hose Ø 70 mm, e.g. welding or handling BizLink LSH 3 整套管线包系统, 轴 1-6, 波纹管 Ø70 mm, 如焊接或搬运	DPS0065
2	KUKA Quantec Serie 2010 bis R3100	Complete system support BizLink LSC, axis 1-6, corrugated hose Ø 70 mm, e.g. welding or handling BizLink LSC 整套管线包系统, 轴 1-6, 波纹管 Ø70 mm, 如焊接或搬运	DPS0066

**Note** > Please contact us for your personal offer regarding empty dresspacks: [factory-automation.bizlinktech.com/contact/](http://factory-automation.bizlinktech.com/contact/)  
**备注** > 联系我们获取空管线包的独立报价: [factory-automation.bizlinktech.com/zh/联系我们/](http://factory-automation.bizlinktech.com/zh/联系我们/)

**Note** > Please contact us for your personal offer regarding empty dresspacks: [factory-automation.bizlinktech.com/contact/](http://factory-automation.bizlinktech.com/contact/)  
**备注** > 联系我们获取空管线包的独立报价: [factory-automation.bizlinktech.com/zh/联系我们/](http://factory-automation.bizlinktech.com/zh/联系我们/)

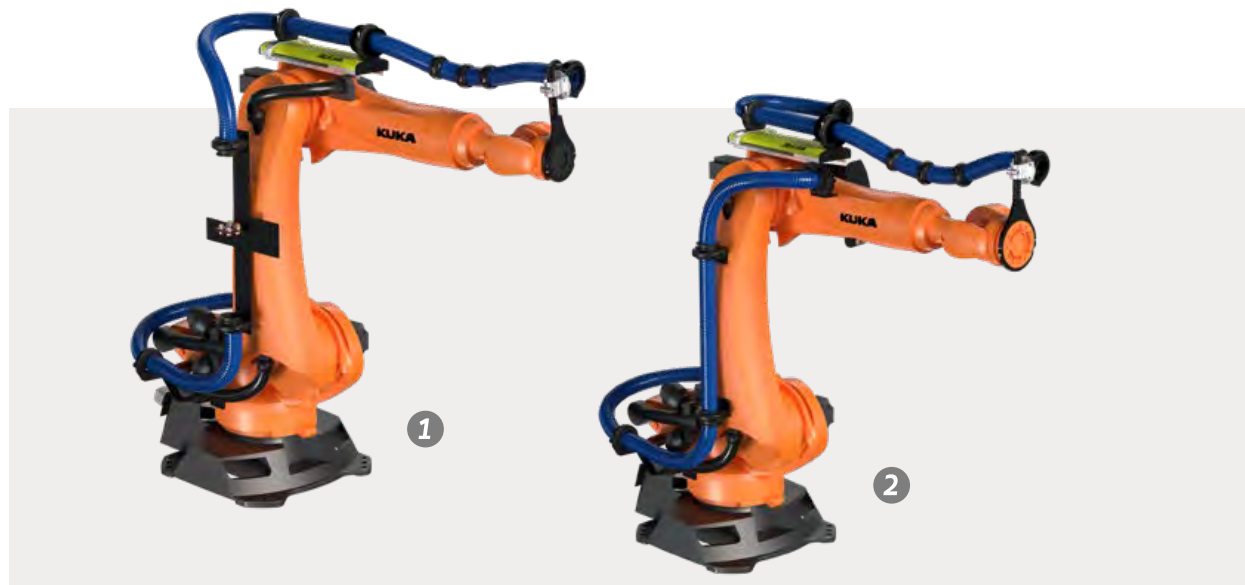

Pos.	Exemplary robot 典型机器人	Description 描述	Article no. 订购号
1	KUKA series 2010, Quantec	Complete system support BizLink dresspack LSH 3, axis 1-6, corrugated hose Ø 70 mm, e.g. spot welding, handling BizLink LSH 3 整套管线包系统, 轴 1-6, 波纹管 Ø70 mm, 如点焊或搬运	DPS0067
2	KUKA Serie 2000, -2010, KR150-R3100	Complete system support BizLink dresspack LSH 3, axis 1-6, corrugated hose Ø 70 mm, e.g. handling BizLink LSH 3 整套管线包系统, 轴 1-6, 波纹管 Ø70 mm, 如搬运	DPS0068

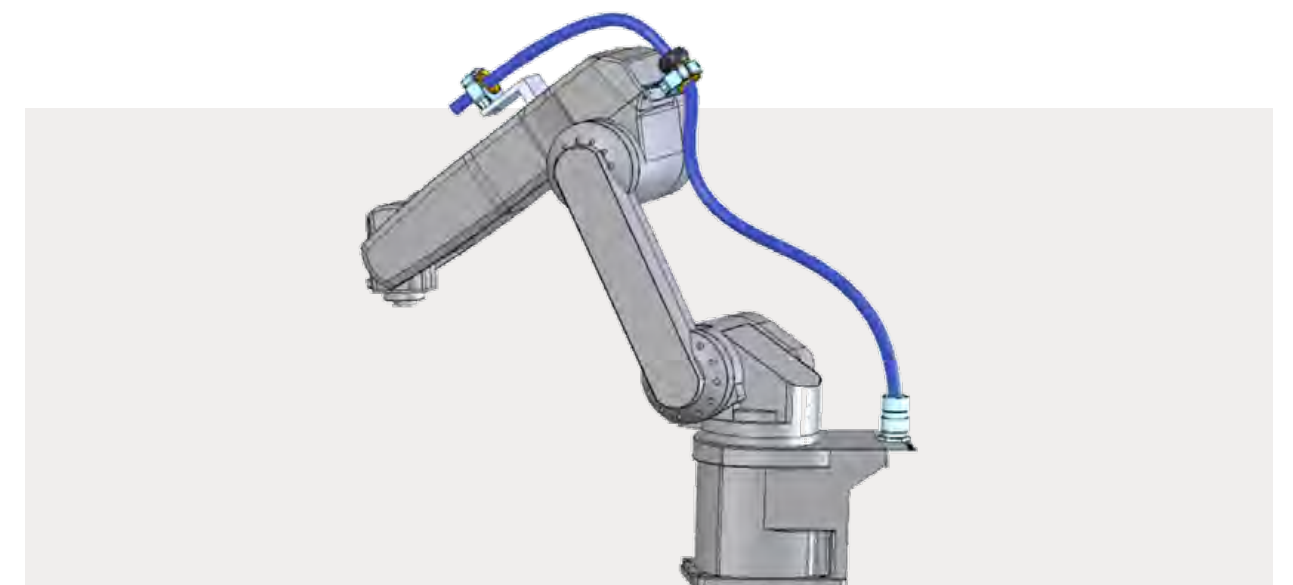

Exemplary robot 典型机器人	Description 描述	Article no. 订购号
MITSUBISHI RV-6SL	Complete system overview axis 1-4, corrugated hose Ø 29 mm, e.g. handling (pick & place) 整套管线包系统, 轴 1-4, 波纹管 Ø29 mm, 如搬运 (拾取和放置)	DPS0022

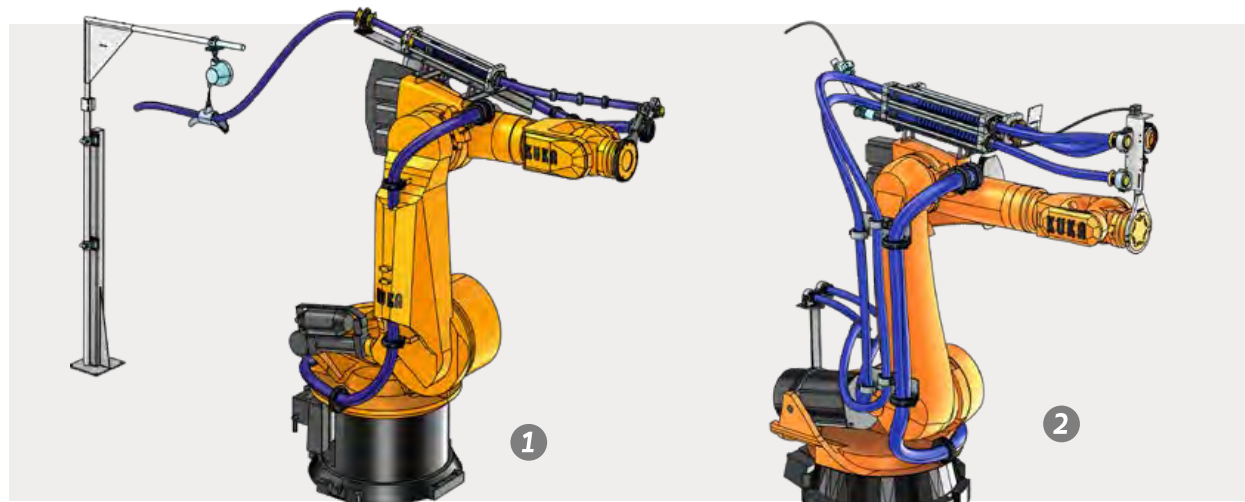

Pos.	Exemplary robot 典型机器人	Description 描述	Article no. 订购号
1	KUKA KR360-2, KR500-2	Complete system support for BizLink dresspack LSH 3 and LSC-line 48, axis 1-6 BizLink LSH 3 和 LSC-Line 48 整套管线包系统, 轴 1-6	DPS0028
2	KUKA KR150-270 series 2000	Complete system support for BizLink dresspack LSC-line, axis 1-6, e.g. laser welding or laser soldering BizLink LSC-Line 整套管线包系统, 轴 1-6, 如激光焊接或激光锡焊	DPS0029

**Note** > Please contact us for your personal offer regarding empty dresspacks: [factory-automation.bizlinktech.com/contact/](http://factory-automation.bizlinktech.com/contact/)  
**备注** > 联系我们获取空管线包的独立报价: [factory-automation.bizlinktech.com/zh/联系我们/](http://factory-automation.bizlinktech.com/zh/联系我们/)

**Note** > Please contact us for your personal offer regarding empty dresspacks: [factory-automation.bizlinktech.com/contact/](http://factory-automation.bizlinktech.com/contact/)  
**备注** > 联系我们获取空管线包的独立报价: [factory-automation.bizlinktech.com/zh/联系我们/](http://factory-automation.bizlinktech.com/zh/联系我们/)





Pos.	Exemplary robot 典型机器人	Description 描述	Article no. 订购号
1	Nachi SRA166-01	Complete system support BizLink dresspack LSH 3, axis 3-6, corrugated hose Ø 70 mm, e.g. welding BizLink LSH 3 整套管线包系统, 轴 3-6, 波纹管 Ø70 mm, 如焊接	DPS0069
2	Nachi SRA210-01	Complete system support BizLink dresspack LSH 3, axis 3-6, corrugated hose Ø 70 mm, parallel guidance, e.g. welding BizLink LSH 3 整套管线包系统, 轴 3-6, 波纹管 Ø70 mm, 平行引导, 如焊接	DPS0070



Pos.	Exemplary robot 典型机器人	Description 描述	Article no. 订购号
1	OTC FD-V350	Complete system support BizLink dresspack LSH 3, axis 1-6, corrugated hose Ø 48/70 mm, e.g. handling BizLink LSH 3 整套管线包系统, 轴 1-6, 波纹管 Ø48/70 mm, 如搬运	DPS0073
2	OTC FD-V350	Complete system support BizLink dresspack LSH 3, axis 1-6, corrugated hose Ø 48/70 mm, e.g. handling, riveting BizLink LSH 3 整套管线包系统, 轴 1-6, 波纹管 Ø48/70 mm, 如搬运、铆接	DPS0074

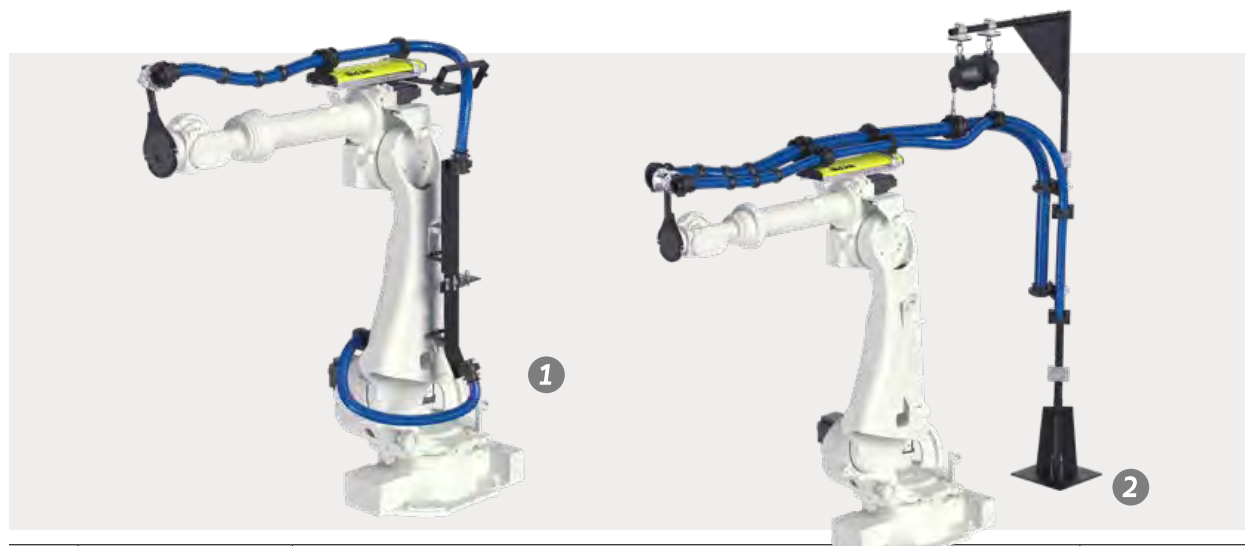

Pos.	Exemplary robot 典型机器人	Description 描述	Article no. 订购号
1	OTC FD-V210, -V166	Complete system support BizLink dresspack LSH 3, axis HIP-6, corrugated hose Ø 48 mm, with cantilever system, e.g. handling BizLink LSH 3 整套管线包系统, 轴 HIP-6, 波纹管 Ø48 mm, 带悬臂系统, 如搬运	DPS0071
2	OTC FD-V166, -V210	Complete system support BizLink dresspack LSH 3, axis HIP-6, corrugated hose Ø 48/70 mm, with cantilever system, parallel guidance, e.g. laser, handling BizLink LSH 3 整套管线包系统, 轴 HIP-6, 波纹管 Ø48/70 mm, 带悬臂系统, 平行引导, 如激光、搬运	DPS0072

**Note** ▶ Please contact us for your personal offer regarding empty dresspacks: [factory-automation.bizlinktech.com/contact/](http://factory-automation.bizlinktech.com/contact/)  
备注 ▶ 联系我们获取空管线包的独立报价: [factory-automation.bizlinktech.com/zh/联系我们/](http://factory-automation.bizlinktech.com/zh/联系我们/)

**Note** ▶ Please contact us for your personal offer regarding empty dresspacks: [factory-automation.bizlinktech.com/contact/](http://factory-automation.bizlinktech.com/contact/)  
备注 ▶ 联系我们获取空管线包的独立报价: [factory-automation.bizlinktech.com/zh/联系我们/](http://factory-automation.bizlinktech.com/zh/联系我们/)



Pos.	Exemplary robot 典型机器人	Description 描述	Article no. 订购号
1	STÄUBLI TX90XL	Complete system support, axis 1-6, corrugated hose Ø 36 mm, electrical and air intake application 整套管线包系统, 轴 1-6, 波纹管 Ø36 mm, 电气和进气应用	DPS0075
2	STÄUBLI TX90L	Complete system support, axis 1-6, corrugated hose Ø 36 mm, e.g. handling 整套管线包系统, 轴 1-6, 波纹管 Ø36 mm, 如搬运	DPS0076



Exemplary robot 典型机器人	Description 描述	Article no. 订购号
Universal Robot, UR10	Complete system support, axis 1-6, corrugated hose Ø 23 mm, e.g. handling (pick & place) or measurement 整套管线包系统, 轴 1-6, 波纹管 Ø23 mm, 如搬运 (拾取和放置) 或测量	DPS0077

**Note** ▶ Please contact us for your personal offer regarding empty dresspacks: [factory-automation.bizlinktech.com/contact/](http://factory-automation.bizlinktech.com/contact/)  
**备注** ▶ 联系我们获取空管线包的独立报价: [factory-automation.bizlinktech.com/zh/联系我们/](http://factory-automation.bizlinktech.com/zh/联系我们/)



Pos.	Exemplary robot 典型机器人	Description 描述	Article no. 订购号
1	MOTOMAN MS210	Complete system support BizLink dresspack LSH 3, axis 1-6, corrugated hose Ø 70 mm, e.g. handling BizLink LSH 3 整套管线包系统, 轴 1-6, 波纹管 Ø70 mm, 如搬运	DPS0078
2	MOTOMAN MS165 / MH180	Complete system support BizLink dresspack LSH 3, axis 1-6, corrugated hose Ø 70 mm, Profinet, e.g. welding or handling BizLink LSH 3 整套管线包系统, 轴 1-6, 波纹管 Ø70 mm, Profinet, 如搬运	DPS0079



Pos.	Exemplary robot 典型机器人	Description 描述	Article no. 订购号
1	MOTOMAN MS210 / MH225	Complete system support BizLink dresspack LSH 3, axis 1-6, corrugated hose Ø 70 mm, Profinet, e.g. welding or handling BizLink LSH 3 整套管线包系统, 轴 1-6, 波纹管 Ø70 mm, Profinet, 如焊接或搬运	DPS0080
2	MOTOMAN MS210	Complete system support BizLink dresspack LSH 3, axis 1-6, corrugated hose Ø 70 mm, e.g. welding (with Duering gun) BizLink LSH 3 整套管线包系统, 轴 1-6, 波纹管 Ø70 mm, 如焊接 (使用杜林枪)	DPS0081

**Note** ▶ Please contact us for your personal offer regarding empty dresspacks: [factory-automation.bizlinktech.com/contact/](http://factory-automation.bizlinktech.com/contact/)  
**备注** ▶ 联系我们获取空管线包的独立报价: [factory-automation.bizlinktech.com/zh/联系我们/](http://factory-automation.bizlinktech.com/zh/联系我们/)





Exemplary robot 典型机器人	Description 描述	Article no. 订购号
MOTOMAN MS165	Complete system support BizLink dresspack LSH 3, axis 1 – 6, corrugated hose Ø 70 mm, e.g. handling BizLink LSH 3 整套管线包系统, 轴 1-6, 波纹管 Ø70 mm, 如搬运	DPS0082

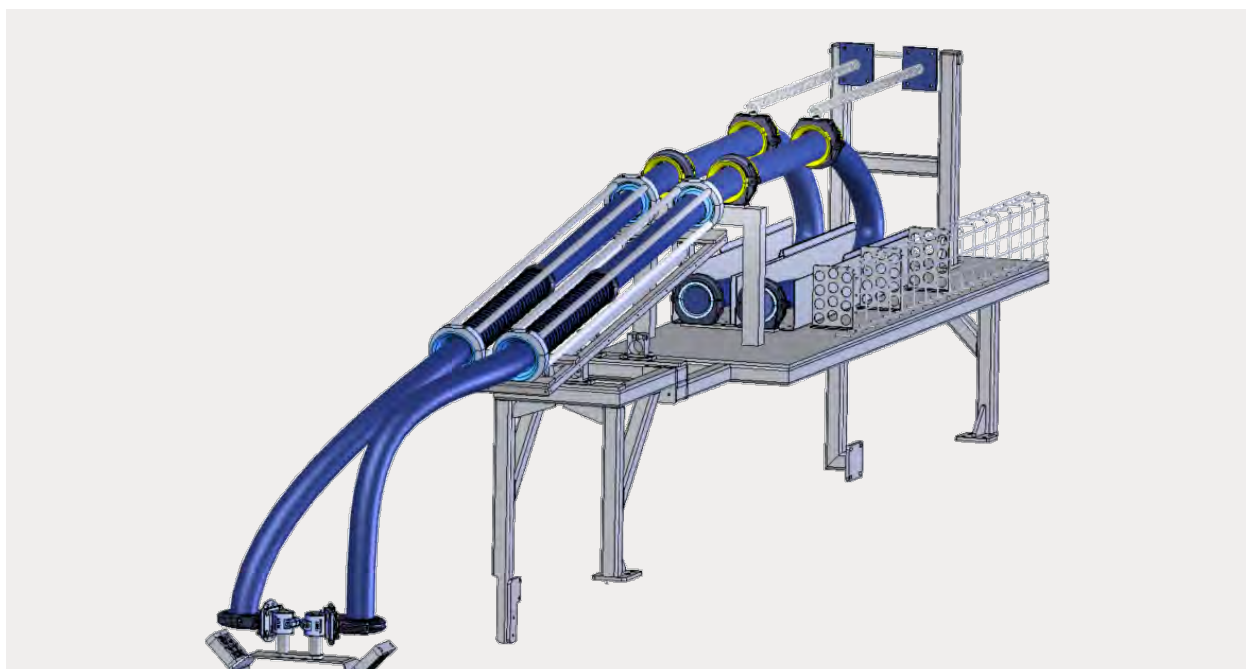

Description 描述	Article no. 订购号
Special machine solution 特种机械解决方案	DPS0027

**Note** > Please contact us for your personal offer regarding empty dresspacks: [factory-automation.bizlinktech.com/contact/](http://factory-automation.bizlinktech.com/contact/)  
**备注** > 联系我们获取空管线包的独立报价: [factory-automation.bizlinktech.com/zh/联系我们/](http://factory-automation.bizlinktech.com/zh/联系我们/)

# Assemblies & components 组件和零件



Our strength is the smart combination of components to assemblies which form a secure and reliable mounted solution for axis 1 through 6 for electrical, communication, and other materials (such as water, air...).

These can be customized for different interfaces, cantilever systems, and baskets – our experience is your advantage. The displayed illustrations are application examples. For each robot type, modifications are possible. We can adjust these assemblies not only for robots but also for special machines, always considering the conditions on-site.

As system suppliers, we develop and supply all the fitting and guiding elements required for smooth operation. Individual support components for fitting and guiding dress-packs, diverse installation fittings and innovative coupling and connector systems are some examples of our broad range of components. Due to top quality materials, longevity and simple handling it is even fun installing these fitting and guiding elements.

The shown colours may differ from the original due to clarity reasons.

我们的解决方案可以巧妙地连接各个部件，行程一个从1 – 6轴安全可靠的管线包，用于无论是电气、通信和其他介质（如水、空气.....）的精准控制。

不同接口、悬吊系统和围栏均可定制——我们的经验就是您的优势。插图所示均为应用范例。对于每款机器人类型，都可能进行修改。在考虑现场条件的情况下，我们不仅为机器人，也可以为特殊设备调整这些组件。

作为系统供应商，我们开发并提供平稳运行所需的所有配件和导向元件，如用于安装和引导管线包的独立支撑组件、各种安装配件以及创新的耦合和连接器系统。由于采用优质材料、使用寿命长且操作简单，安装这些导向元器组件都甚至变得非常有趣。

由于清晰度的原因，显示的颜色可能与实物的颜色有差别。



Pos.	Description 描述	Article no. 订购号
1	Assembly cantilever system adjustable height 悬吊系统, 可调高度	ASS0041
2	Assembly cantilever system 悬吊系统	ASS0042
3		ASS0043
4		ASS0044

Note: Adjustments and other cantilever systems on request.  
备注: 根据特定需求, 提供不同调整和其他悬吊系统。

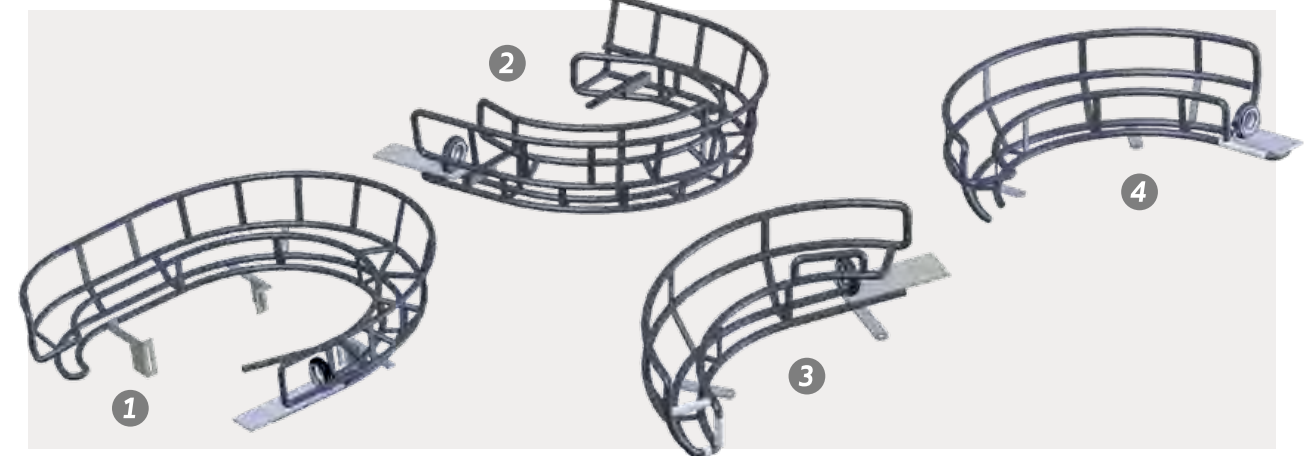

Pos.	Description 描述	Article no. 订购号
<b>Available for all kinds of industrial robots   可用于各类工业机器人</b>		
1	for FANUC M900iA 用于 FANUC M900iA	ASS0045
2	for Motoman UP130/165, corrugated hose Ø 70/56 mm 用于 Motoman UP130/165, 波纹管 Ø70/56 mm	ASS0046
3	for Motoman UP130/165, corrugated hose Ø 56 mm 用于 Motoman UP130/165, 波纹管 Ø56 mm	ASS0047
4	for KUKA KR 150-270 Series 2000 用于 KUKA KR 150-270 系列2000	ASS0048

Note: Adjustments and other baskets on request.  
备注: 根据特定需求, 提供不同调整和其他围栏。



Exemplary Interface Axis 1  
轴 1 接口板



Exemplary Interface Axis 2  
轴 2 接口板

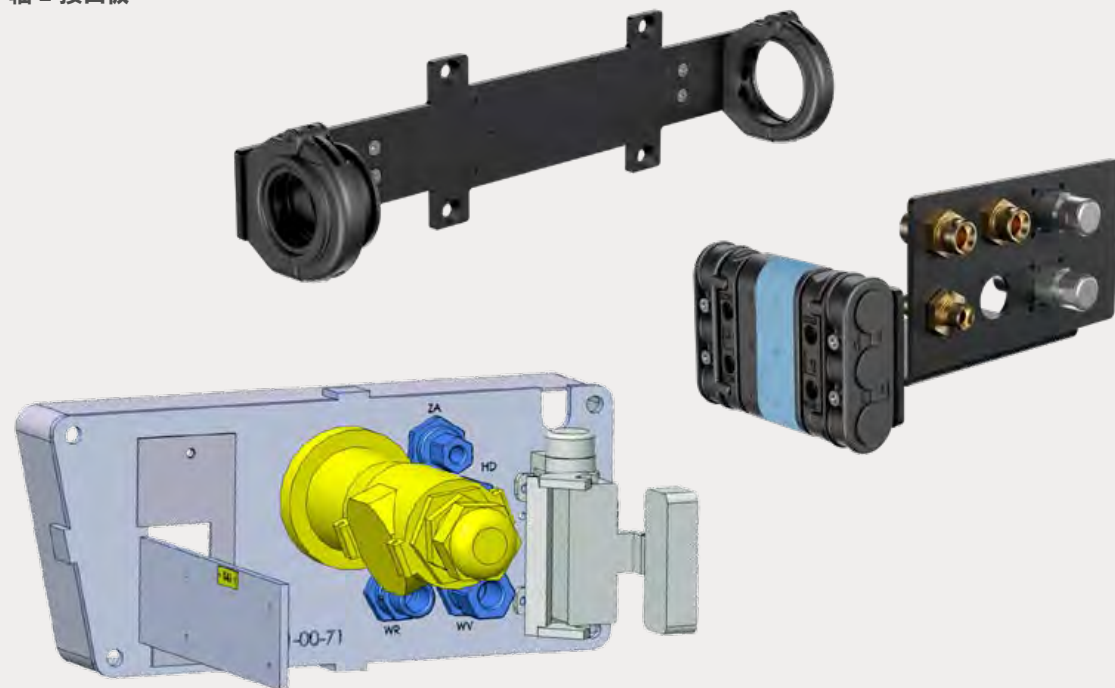

Exemplary Interface Axis 3  
轴 3 接口板

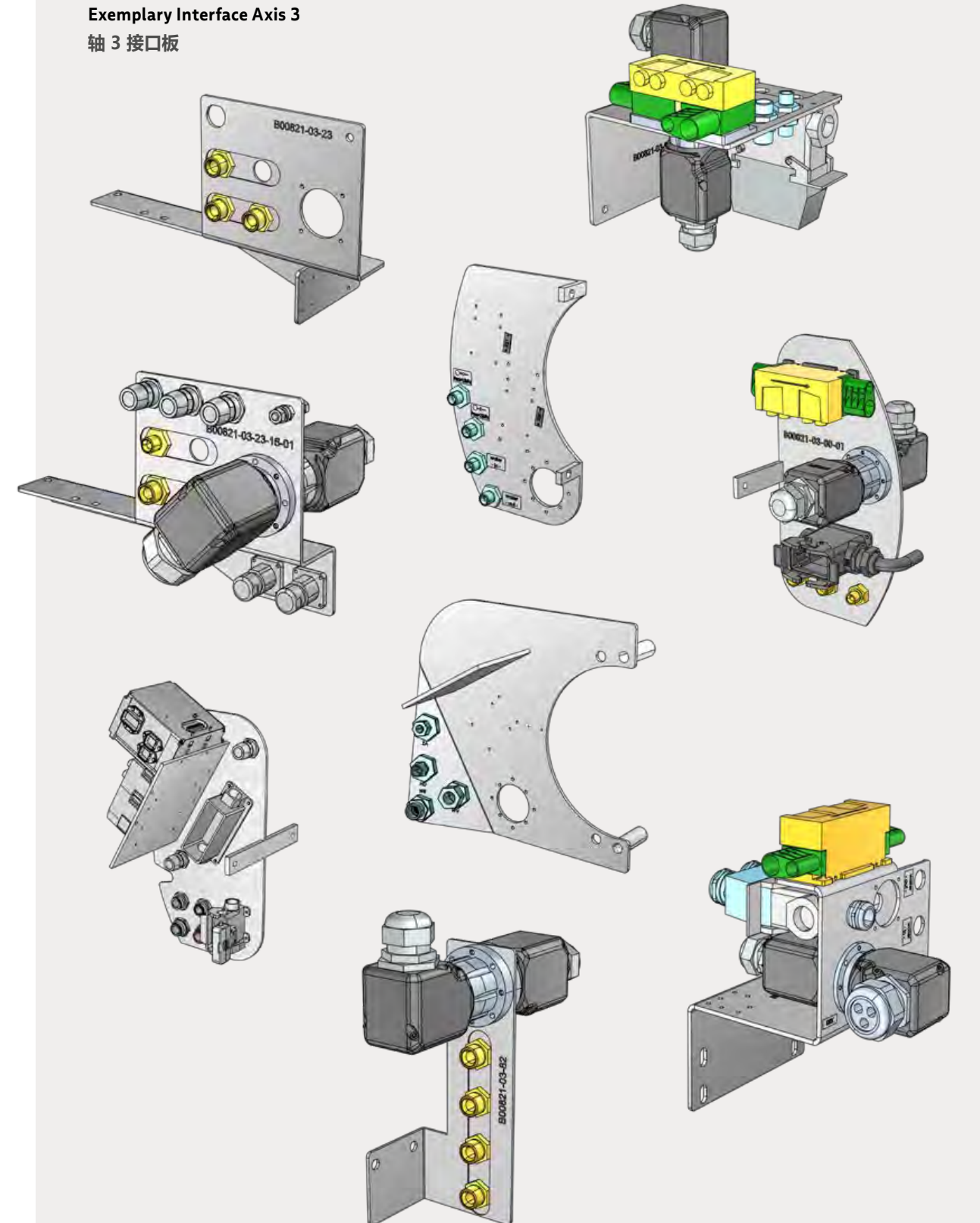

Note: Further versions on request. Arbitrarily expandable.  
备注: 可提供更多版本, 并任意扩展。

## Components for corrugated hoses 波纹管配件



Pos.	Description 描述	Material 材质	Range of temperature 温度范围	Article no. 订购号
1	Cable clamp 卡箍	PA	0° C to max. +60° C ** 0° C 至 60° C (最大) **	CCH0045
		PA	0° C to max. +60° C ** 0° C 至 60° C (最大) **	CCH0046
		Al Si 12 Al Si 12		CCH0001
2		PA PA	0° C to max. +60° C ** 0° C 至 60° C (最大) **	CCH0047

\* Cable clamp suitable for further diameters on request. / 根据特定需求, 提供不同卡箍和直径。

\*\* For conversion in Fahrenheit, please check page 65. / 如需转换为华氏温度, 请参阅P65。



Pos.	Description 描述	Material 材质	Range of temperature 温度范围	Article no. 订购号
1	Cable clamp 卡箍	PA PA	0° C to max. +60° C ** 0° C 至 60° C (最大) **	CCH0002
2		Al Si 12 Al Si 12		CCH0048

\* Cable clamp suitable for further diameters on request. / 根据特定需求, 提供不同卡箍和直径。

\*\* For conversion in Fahrenheit, please check page 65. / 如需转换为华氏温度, 请参阅P65。



Pos.	Description 描述	Material 材质	Range of temperature 温度范围	Article no. 订购号
1	Ball joint termination 球头关节	PA	0° C to max. +60° C ** 0° C 至 60° C (最大) **	CCH0049
		PA	0° C to max. +60° C ** 0° C 至 60° C (最大) **	CCH0050
		PA	0° C to max. +60° C ** 0° C 至 60° C (最大) **	CCH0003
2		with half-shell Ø 70 mm * 含瓦片 Ø70 mm *		CCH0004
		with half-shell Ø 95 mm * 含瓦片 Ø95 mm *		CCH0051

\* Ball joint termination suitable for other Ø on request. / 根据特定需求, 提供不同球头关节和直径。

\*\* For conversion in Fahrenheit, please check page 65. / 如需转换为华氏温度, 请参阅P65。

Pos.	Description 描述	Material 材质	Range of temperature 温度范围	Article no. 订购号
3	Protection donut 防擦球	PA	0° C to max. +60° C ** 0° C 至 60° C (最大) **	CCH0052
		PA	0° C to max. +60° C ** 0° C 至 60° C (最大) **	CCH0053
		PA	0° C to max. +60° C ** 0° C 至 60° C (最大) **	CCH0005
		PA	0° C to max. +60° C ** 0° C 至 60° C (最大) **	CCH0006
		PA	0° C to max. +60° C ** 0° C 至 60° C (最大) **	CCH0054

\* Protection suitable for other Ø on request. / 根据特定需求, 提供不同防擦球和直径。

\*\* For conversion in Fahrenheit, please check page 65. / 如需转换为华氏温度, 请参阅P65。



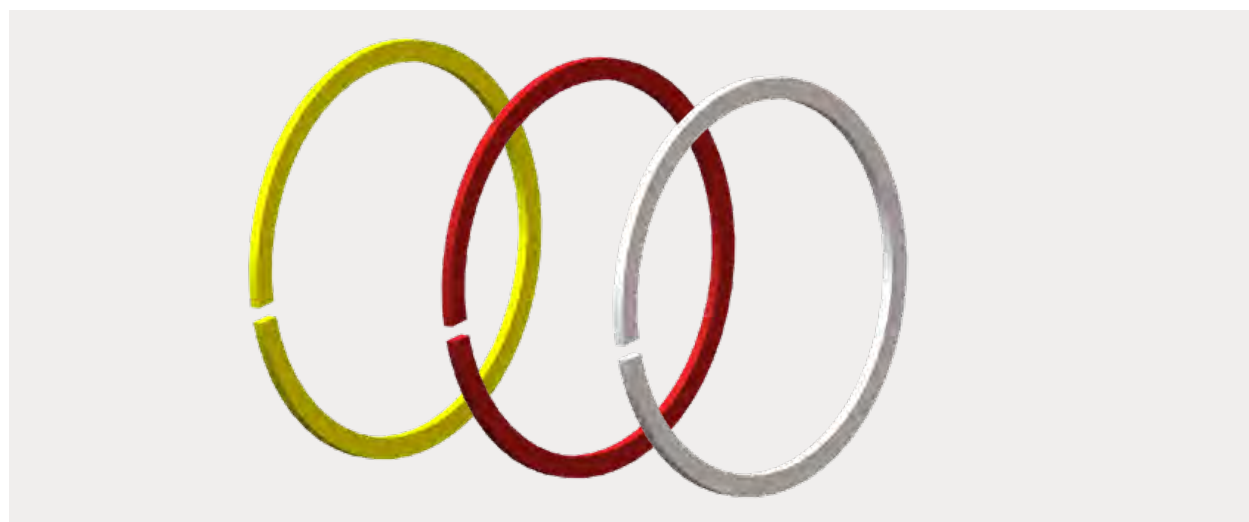

Description 描述	Material 材质	Range of temperature 温度范围	Article no. 订购号
Marker ring, Ø 48 mm slotted 标记环, Ø 48 mm, 开槽	● red / 红	0° C to max. +60° C * 0° C 至 60° C (最大) *	CCH0055
	● yellow / 黄		CCH0056
	○ white / 白		CCH0057
Marker ring, Ø 70 mm slotted 标记环, Ø 70 mm, 开槽	● red / 红		CCH0007
	● yellow / 黄		CCH0008
	○ white / 白		CCH0009
Marker ring, Ø 95 mm slotted 标记环, Ø 95 mm, 开槽	● red / 红		CCH0058
	● yellow / 黄		CCH0059
	○ white / 白		CCH0060

\* For conversion in Fahrenheit, please check page 65. / 如需转换为华氏温度, 请参阅P65.

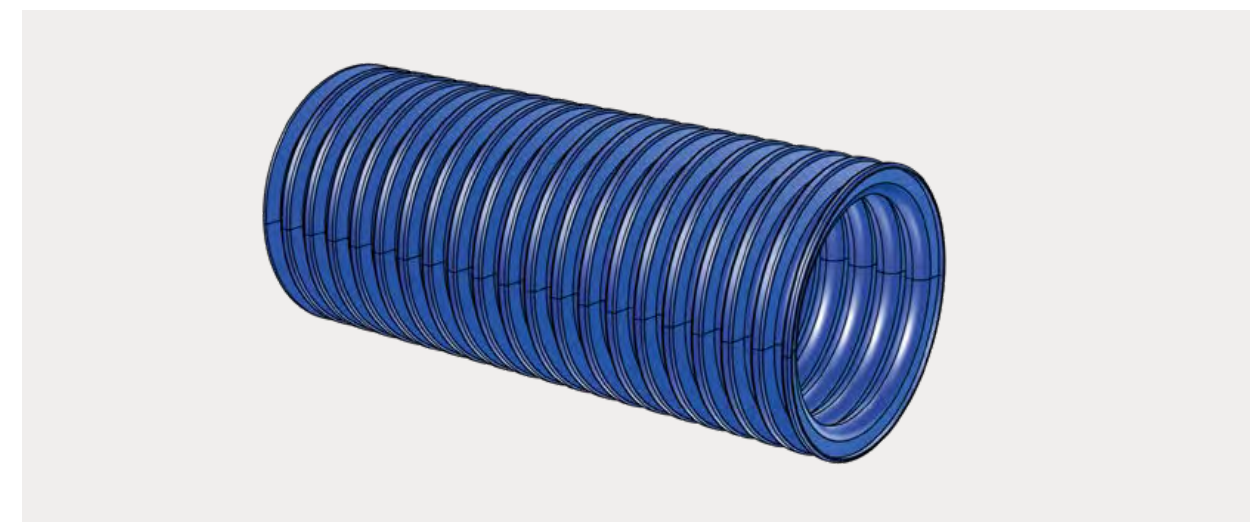

Description 描述	Packaging unit 包装	Outer diameter 外径	Inner diameter 内径	Article no. 订购号
Corrugated hose BizLink proflex, Ø 17 mm BizLink proflex 波纹管, Ø 17 mm	50 m 50 m	21 mm 21 mm	16 mm 16 mm	CCH0061
Corrugated hose BizLink proflex, Ø 23 mm BizLink proflex 波纹管, Ø 23 mm	50 m 50 m	28 mm 28 mm	22.5 mm 22,5 mm	CCH0062
<b>Material</b> 材质	<b>Range of temperature</b> 温度范围		<b>Toxicity</b> 毒性	
Special thermoplast 特殊热塑性塑料	-40° C to +55° C * -40° C 至 55° C (最大) *		Free of halogen and cadmium 无卤、镉	
<b>Resistance against</b> 可抵抗				
Weak and organic acid, lye, inorganic salt, amine, alcohol, grease 弱酸、有机酸、碱、无机盐、胺、酒精、油脂				

Description 描述	Packaging unit 包装	Outer diameter 外径	Inner diameter 内径	Article no. 订购号
Corrugated hose BizLink proflex, Ø 29 mm BizLink proflex 波纹管, Ø 29 mm	50 m 50 m	34.4 mm 34,4 mm	29 mm 29 mm	CCH0010
Corrugated hose BizLink proflex, Ø 36 mm BizLink proflex 波纹管, Ø 36 mm	30 m 30 m	42.5 mm 42,5 mm	36.5 mm 36,5 mm	CCH0011
Corrugated hose BizLink proflex, Ø 48 mm BizLink proflex 波纹管, Ø 48 mm	30 m 30 m	54.5 mm 54,5 mm	47.5 mm 47,5 mm	CCH0012
Corrugated hose BizLink proflex, Ø 70 mm BizLink proflex 波纹管, Ø 70 mm	30 m 30 m	80 mm 80 mm	67.5 mm 67,5 mm	CCH0013
Corrugated hose BizLink proflex, Ø 95 mm BizLink proflex 波纹管, Ø 95 mm	20 m 20 m	106 mm 106 mm	91.5 mm 91,5 mm	CCH0014
<b>Material</b> 材质	<b>Range of temperature</b> 温度范围		<b>Toxicity</b> 毒性	
Special thermoplast 特殊热塑性塑料	-50° C to +110° C * -50° C 至 110° C (最大) *		Free of halogen and cadmium 无卤、镉	
<b>Resistance against</b> 可抵抗				
Alcohol, greases, fuels, mineral oils 酒精、油脂、燃料、矿物油				

\* For conversion in Fahrenheit, please check page 65. / 如需转换为华氏温度, 请参阅P65.



Description 描述	Material 材质	Range of temperature 温度范围	Article no. 订购号
Ø 36 mm	POM POM	0° C to max. +100° C * 0° C 至 100° C (最大) *	CCH0063
Ø 48 mm	PA PA	0° C to max. +60° C * 0° C 至 60° C (最大) *	CCH0015
Ø 70 mm	PA PA	0° C to max. +60° C * 0° C 至 60° C (最大) *	CCH0016
Ø 95 mm	POM POM	0° C to max. +100° C * 0° C 至 100° C (最大) *	CCH0064

\* For conversion in Fahrenheit, please check page 65. / 如需转换为华氏温度, 请参阅P65.



Pos.	Description 描述	Material 材质	Range of temperature 温度范围	Article no. 订购号
1	Half-shell Ø 48 mm * 瓦片 Ø 48 mm *	PA PA	0° C to max. +60° C ** 0° C 至 60° C (最大) **	CCH0065
	Half-shell Ø 70 mm * 瓦片 Ø 70 mm *			CCH0018
Half-shell for cable star Ø 70 mm * 夹线器瓦片 Ø 70 mm *	CCH0019			
Half-shell flex for fixation of corrugated hose and cable star Ø 70 mm *, 2 in 1 part combination 夹线器及波纹管瓦片 Ø 70 mm *, 2 合 1	CCH0066			
Half-shell Ø 95 mm * 瓦片 Ø 95 mm *	CCH0067			

\* Further Ø on request. / 根据特定要求, 提供不同直径。

\*\* For conversion in Fahrenheit, please check page 65. / 如需转换为华氏温度, 请参阅P65.



Description 描述	Material 材质	Range of temperature 温度范围	Article no. 订购号
Adapter Ø 48 mm for corrugated hoses Ø 48 mm in cable clamp Ø 70 mm (LSH dresspack LSH-line or LSC) Ø 48 mm 转接球, 转接 Ø 48 mm 波纹管与 Ø 70 mm 卡箍 (LSH-Line 或 LSC 管线包)	PA PA	0° C to max. +60° C * 0° C 至 60° C (最大) *	CCH0017

\* For conversion in Fahrenheit, please check page 65. / 如需转换为华氏温度, 请参阅P65.



Description 描述	Material 材质	Range of temperature 温度范围	Article no. 订购号
Connector for corrugated hose Ø 70 mm 波纹管连接球 Ø 70 mm	PA PA	0° C to max. +60° C * 0° C 至 60° C (最大) *	CCH0079

\* For conversion in Fahrenheit, please check page 65. / 如需转换为华氏温度, 请参阅P65.





Description 描述	Material 材质	Article no. 订购号
Adapter plate for the use between bracket and tube clamp piece, mainly suitable for bracket Ø 48 mm and 70 mm 用于支架与波纹管卡箍之间的转接盘, 主要适用于 Ø48 mm、Ø 70 mm 的支架	Al Si 12 Al Si 12	CCH0020

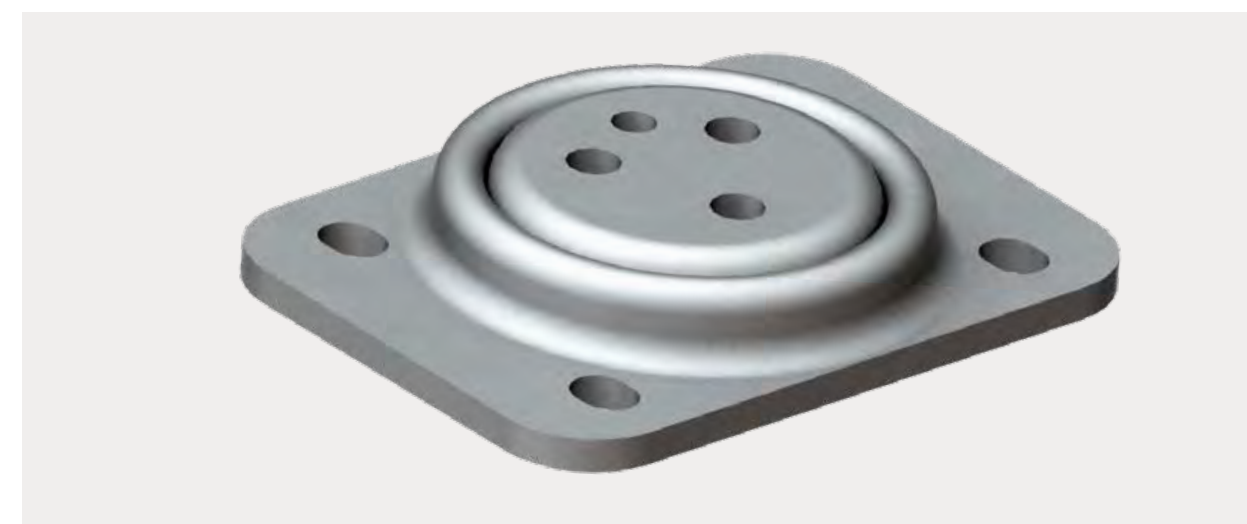

Description 描述	Material 材质	Article no. 订购号
Swivel plate, 120 x 85 mm 旋转板, 120 x 85 mm	Steelplate with 2 lines of balls, galvanized 双排滚珠镀锌钢板	CCH0025

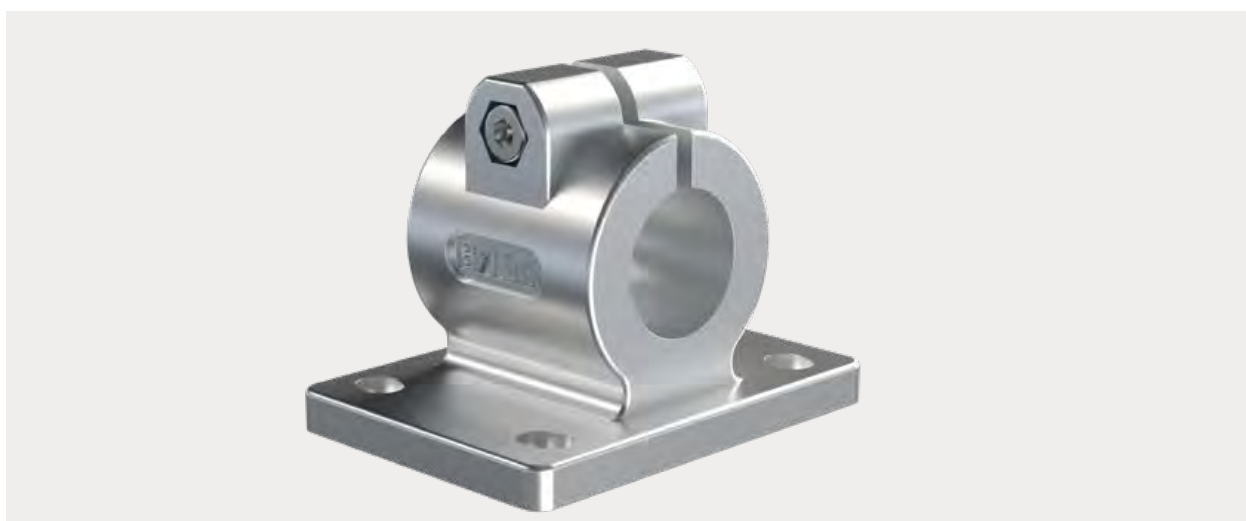

Description 描述	Material 材质	Article no. 订购号
RK 30 suitable for wrist-support axis 6 with tube Ø 30 mm 适用于含 Ø30 mm 管的6轴支架	Al Si 12 Al Si 12	CCH0021
RK 32 suitable for wrist-support axis 6 with tube Ø 32 mm 适用于含 Ø32 mm 管的6轴支架		CCH0022
RK 34 suitable for wrist-support axis 6 with tube Ø 34 mm 适用于含 Ø34 mm 管的6轴支架		CCH0023
RK 40 suitable for wrist-support axis 6 with tube Ø 40 mm 适用于含 Ø40 mm 管的6轴支架		CCH0024



Pos.	Description 描述	Material 材质	Range of temperature 温度范围	Article no. 订购号
1	Corrugated hose end piece Ø 48 mm 波纹管端头 48 mm	PA	0° C to max. +60° C * 0° C bis max. +60° C *	CCH0029
2	Corrugated hose end piece Ø 70 mm 波纹管端头 70 mm	PA		CCH0030

\* For conversion in Fahrenheit, please check page 65. / 如需转换为华氏温度, 请参阅P65.

Note: For spare part business only.

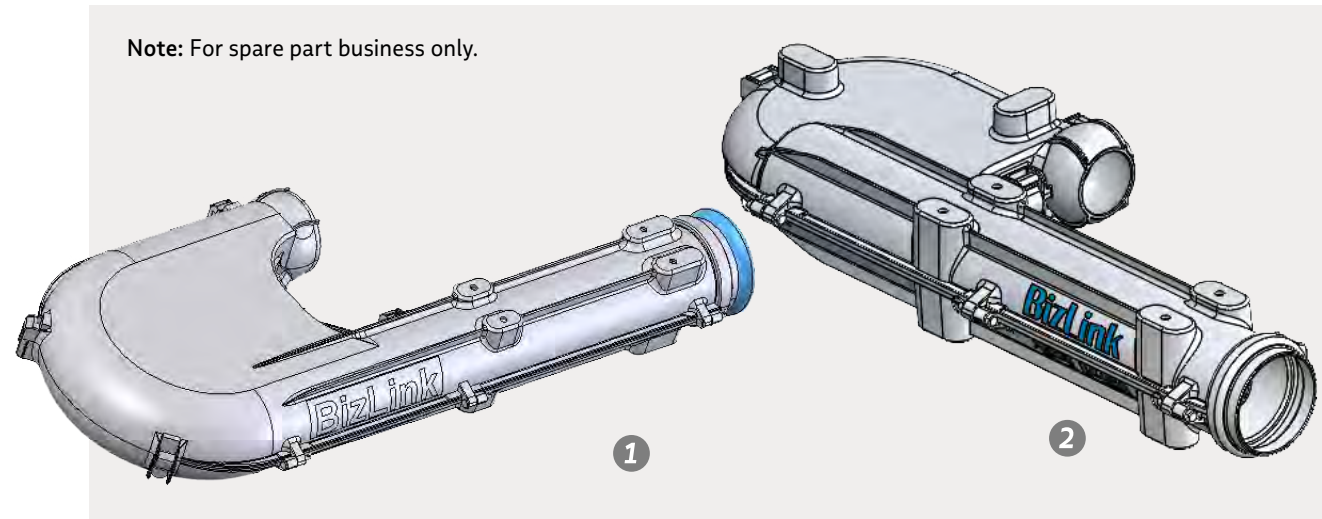

Pos.	Description 描述	Material 材质	Range of temperature 温度范围	Article no. 订购号
1	BizLink LSH-line for corrugated hose Ø 48 mm and Ø 70 mm, 920 x 407 x 121 mm (length x width x height) 波纹管 Ø48 mm、Ø70 mm, 920 x 407 x 121 mm (长 x 宽 x 高)	PP PP	dependent on the hose/tube used 取决于所用的软管和管子	CCH0031
2	BizLink SLS-line for corrugated hose Ø 48 mm 772 x 303 x 110 mm (length x width x height) 波纹管 Ø48 mm, 772 x 303 x 110 mm (长 x 宽 x 高)	PMC PMC	dependent on the hose/tube used 取决于所用的软管和管子	CCH0032



Description 描述	Material 材质	Article no. 订购号
BizLink LSC-line 70 Cover BizLink LSC-line 70 炮筒	for special applications, reducible down to Ø 48 mm. 用于特殊应用, 可缩小至 48 mm	ST, AL, PA, PUR ST, AL, PA, PUR

Further colors on request ● ● ●



Pos.	Description 描述	Material 材质	Article no. 订购号
1	BizLink LSH 3 retract system BizLink LSH 3 回缩系统	AL AL	CCH0068
2	BizLink LSH 3 adapter brackets BizLink LSH 3 转接头支架	AL SI 12 AL SI 12	CCH0070

Note: Special applications like parallel guidance or combined diameters or stroke variations on request. RAL coloring on request.  
备注: 根据特定需求, 提供特种应用, 如平行引导、不同组合的直径或行程。RAL 颜色可选。



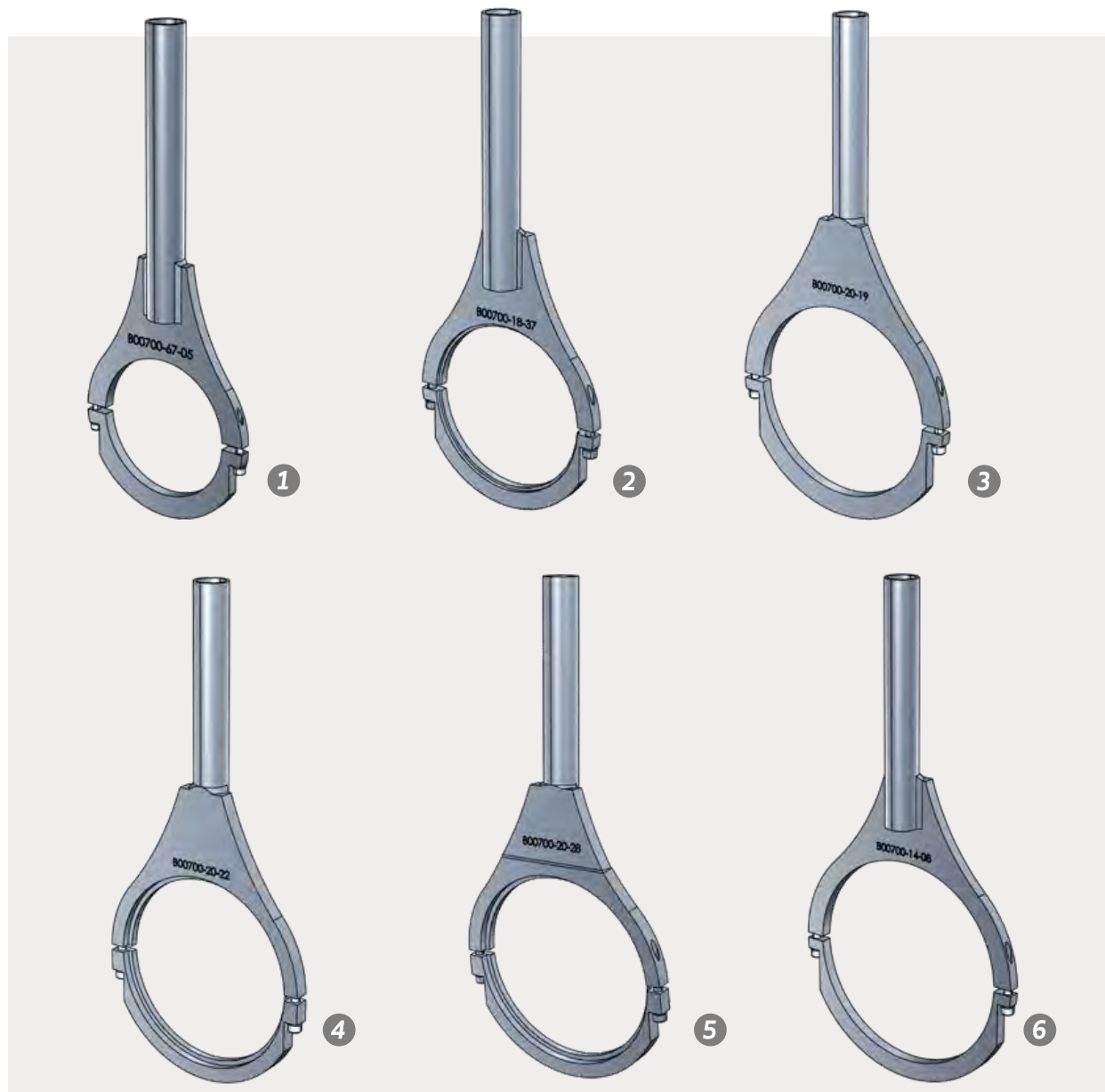

Pos.	Description 描述	for Robot types 适配机器人型号	Material 材质	Range of temperature 温度范围	Article no. 订购号
1	Protection ring, axis 4 4轴保护套	FANUC R2000iC	PA PA	-20° C to max. +80° C * -20° C 至 80° C (最高) *	CCH0074
		FANUC M900iB 360-280L			CCH0075
		FANUC R2000iC 270/210L, M900iB 700/400L			CCH0076
2	Protection cap, axis 4 4轴保护盖	FANUC R2000iC 270/210L, M900iB 700/400L			CCH0077
		FANUC M900iA, iB (except 280), R2000iB			CCH0078

\* For conversion in Fahrenheit, please check page 65. / 如需转换为华氏温度, 请参阅P65.

Pos.	Description 描述	for Robot types 适配机器人型号	Material 材质	Article no. 订购号
1	Ø 125 mm, tube Ø 32 mm Ø 125 mm, 管子 Ø 32 mm	ABB IRB 4400	Steel 钢	CCH0033
2	Ø 160/166 mm, tube Ø 33.7 mm Ø 160/166 mm, 管子 Ø 33.7 mm	FANUC R2000		CCH0034
3	Ø 200 mm, tube Ø 33.7 mm Ø 200 mm, 管子 Ø 33.7 mm	ABB IRB6600, 6620, 6640, 6650		CCH0035
4	Ø 190/200 mm, tube Ø 33.7 mm Ø 190/200 mm, 管子 Ø 33.7 mm	KUKA KR 150/180/210/240/270 C2		CCH0036
5	angled 8°, Ø 200 mm, tube Ø 33.7 mm 8°角, Ø 200 mm, 管子 Ø 33.7 mm	KUKA KR 150/180/210/240/270 C2		CCH0037
6	Ø 220 mm, tube Ø 33.7 mm Ø 220 mm, 管子 Ø 33.7 mm	KUKA KR500, KR 360/1, KR 350/2		CCH0038

Further wrist-supports on request. / 直径根据特定需求, 提供不同的支架。

## Accessories 配件



Description 描述	Article no. 订购号	Example of assembly
Cable star Ø 70 mm for ball joint termination, individually drilled holes 夹线器 Ø70 mm 用于球头关节, 可单独开孔	CCH0039	Bracket Ø 70 mm + ball joint termination + cable star Ø 70 mm 支架 Ø70 mm + 球头关节 + 夹线器 Ø70 mm
Cable star long Ø 70 mm for ball joint termination, individually drilled holes 长款夹线器 Ø70 mm 用于球头关节, 可单独开孔	CCH0040	Bracket Ø 70 mm + ball joint termination + cable star long Ø 70 mm 支架 Ø70 mm + 球头关节 + 长款夹线器 Ø70 mm
Cable star long Ø 48 mm for ball joint termination 长款夹线器 Ø48 mm, 用于球头关节	CCH0041	Bracket Ø 48 mm + ball joint termination Ø 48 mm + cable star long Ø 48 mm 支架 Ø48 mm + 球头关节 Ø48 mm + 长款夹线器 Ø48 mm
Cable star Ø 48 mm for protection 夹线器 Ø48 mm 保护罩	CCH0042	Protection Ø 48 mm + cable star Ø 48 mm 保护 Ø48 mm + 夹线器 Ø48 mm
Cable star Ø 48 mm for ball joint termination 夹线器 Ø48 mm, 用于球头关节	CCH0043	Bracket Ø 48 mm + ball joint termination Ø 48 mm + cable star Ø 48 mm 支架 Ø48 mm + 球头关节 Ø48 mm + 夹线器 Ø48 mm
Cable star Ø 95 mm for ball joint termination 夹线器 Ø95 mm, 用于球头关节	CCH0044	Bracket Ø 95 mm + ball joint termination Ø 95 mm + cable star Ø 95 mm 支架 Ø95 mm + 球头关节 Ø95 mm + 夹线器 Ø95 mm

Note: The drilled holes of the cable stars will follow according to the application after placing the order.  
备注: 下单后, 夹线器的钻孔将依据应用而定。

## Components for smooth tube systems 光滑配管组件



Description 描述	Article no. 订购号
Universal metal support 通用金属支架	min. height 最小高度
	50 mm height 50 mm 高
	100 mm height 100 mm 高
	150 mm height 150 mm 高
for single bracket 用于单卡箍	
Additional robot-specific assemblies upon request. 根据特定需求, 提供额外的机器人专用组件。	



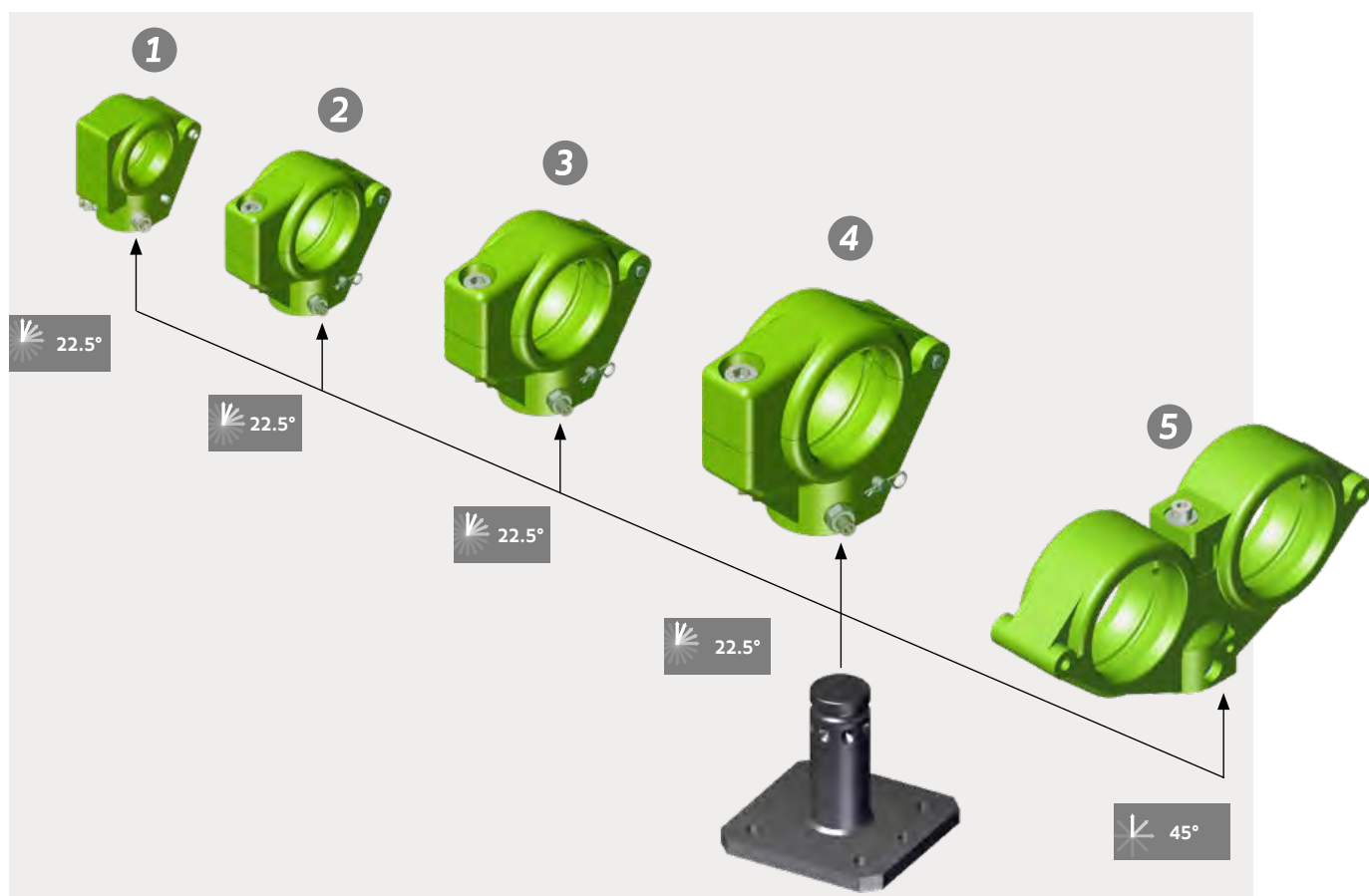

Pos.	Description 描述			Article no. 订购号
1		Ø 40 mm		CST0005
2	Rotating single bracket 旋转调节单卡箍	Ø 60 mm	adjustable every 22.5° 可调 22.5°/次	CST0006
3		Ø 80 mm		CST0007
4		Ø 100 mm		CST0008

Pos.	Description 描述			Article no. 订购号
5	Rotating double bracket 旋转调节双卡箍	Ø 80 + 40 mm	adjustable every 45° 可调 45°/次	CST0009
		Ø 80 + 60 mm		CST0010
		Ø 80 mm		CST0011

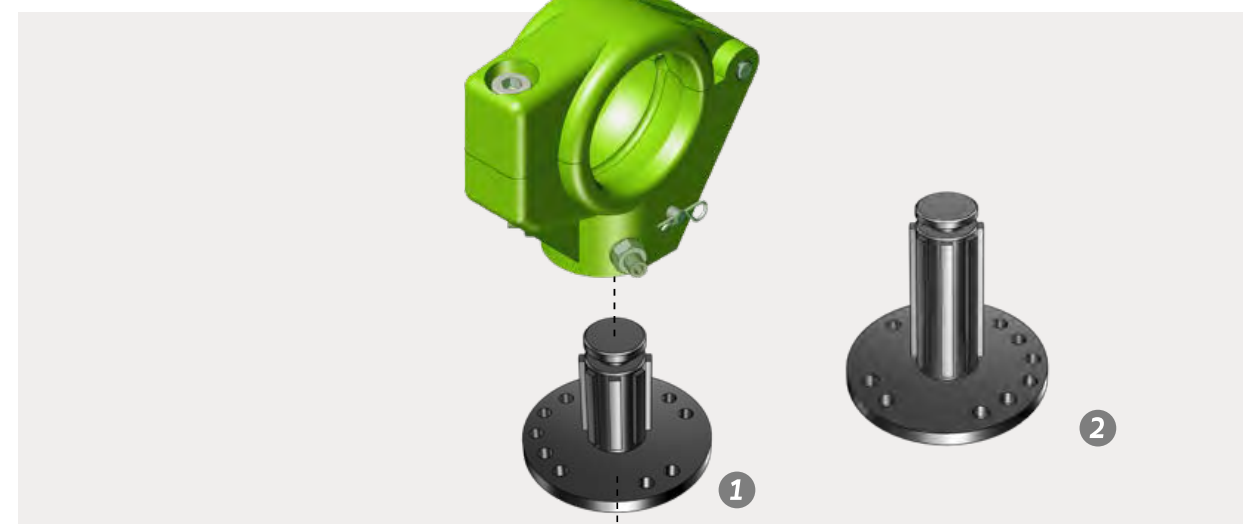

Pos.	Description 描述			Article no. 订购号
1	Fluted metal support 凹槽金属支架	min. height for single bracket 用于单卡箍的最低高度		CST0012
2		100 mm high, for single bracket		CST0013

Additional robot-specific assemblies upon request.  
根据特定需求, 提供额外的机器人专用组件。

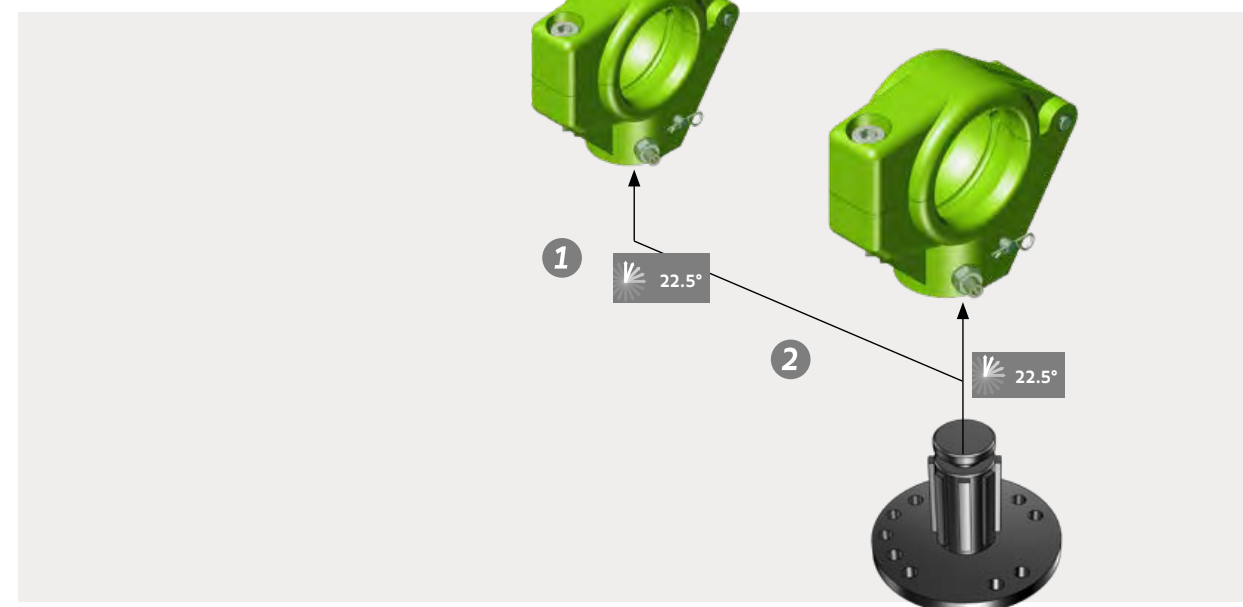

Pos.	Description 描述			Article no. 订购号
1	Adjustable single bracket 可调节单卡箍	Ø 60 mm	adjustable every 22.5° 可调 22.5°/次	CST0014
2		Ø 80 mm		CST0015

## Components for light weight and collaborative robots 用于轻量级机器人和协作机器人的组件

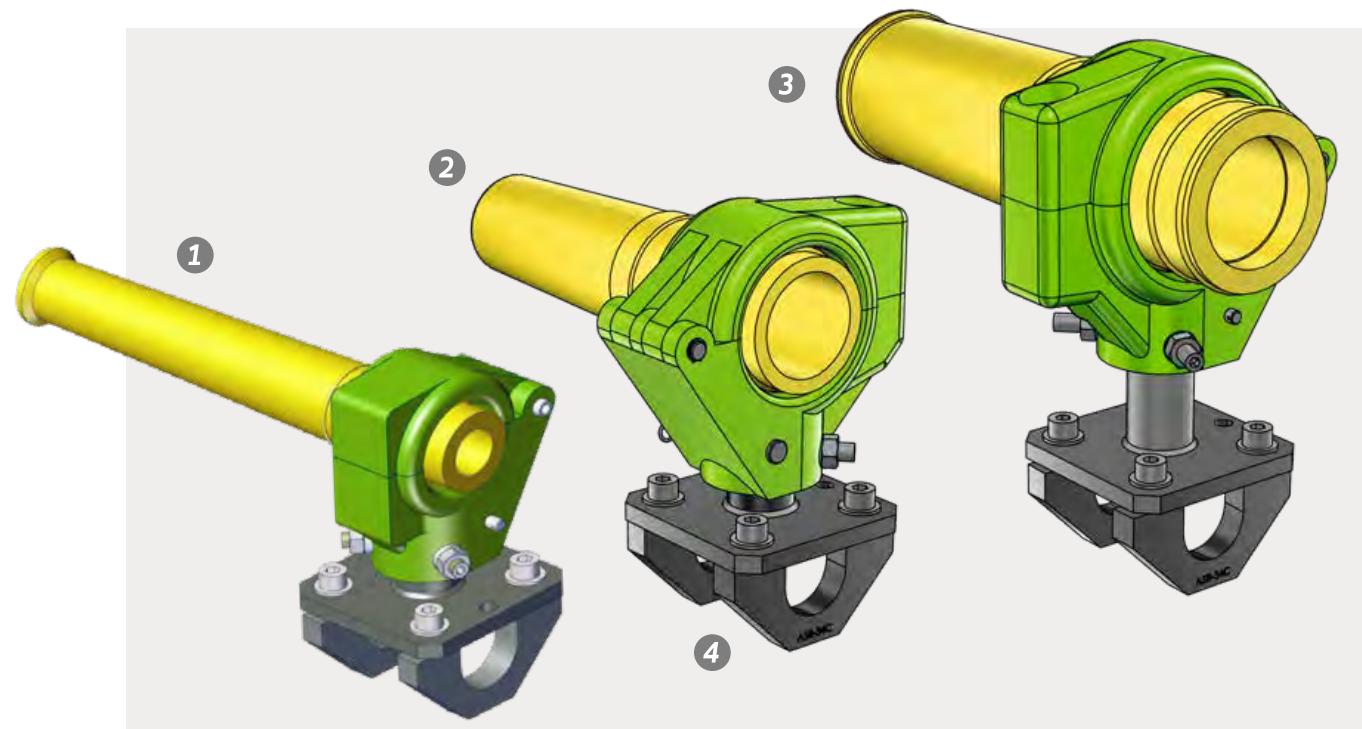

These assembly examples show yellow rotating boots, the corresponding brackets and metal supports as well as tube clamps for pipe Ø 34 mm.

上述组件示例展示了黄色旋转杆、相应的支架、金属支架，以及适配 Ø 34mm 管子的管夹。

Further BizLink B-Flex complete sets for ABB, FANUC, Kuka, Yaskawa and others in preparation.  
更多适配 ABB、FANUC、Kuka、Yaskawa 等机器人的 BizLink B-Flex 完整方案正在陆续筹备中。



Pos.	Description 描述	Inner Ø	Suitable for universal bracket	Article no. 订购号
1	Yellow rotating boot 黄色旋转杆	23 mm	CST0005	CST0016
		24 mm		CST0017
		27 mm		CST0018
2	Yellow rotating boot 黄色旋转杆	36 mm	CST0006/CST0014	CST0019
		41 mm		CST0020
		45 mm		CST0021
		48.5 mm		CST0022
		51 mm		CST0023
3	Yellow rotating boot 黄色旋转杆	54 mm	CST0007/CST0033	CST0024
		55 mm		CST0025
		57 mm		CST0026
		59 mm		CST0027
		60.5 mm		CST0028
		62 mm		CST0029
		64 mm		CST0030
		66 mm		CST0031
4	Tube clamp for pipe Ø 34 mm (2x) 管夹, 适配 Ø 34mm (2x) 管子			CST0032

Pos. 组件	Description	描述	Robot type 机器人型号	Article no. 订购号
A B	<b>BizLink B-Flex Kit short</b> 10x hook and loop fasteners 30 x 360 mm 5x round holders	缩短版 BizLink B-Flex 组件 10x 尼龙搭扣 (30 x 360 mm) 5x 底座	all / 所有类型	CLC0001
A B	<b>BizLink B-Flex Kit long</b> 10x hook and loop fasteners 30 x 460 mm 5x round holders	加长版 BizLink B-Flex 组件 10x 尼龙搭扣 (30 x 460 mm) 5x 底座	all / 所有类型	CLC0002
A B C D	<b>BizLink B-Flex complete set UR 10 - Ø 23</b> 5x hook and loop fasteners 30 x 460 mm 5x round holders 1x holder axis 6 with wrist support Ø 63 mm 1x corrugated hose Ø 23 mm blue, length 3 m	UR 10 - Ø 23 规格的整套 BizLink B-Flex 系统 5x 尼龙搭扣 (30 x 460 mm) 5x 底座 1x 六轴带法兰支架 Ø 63 mm 1x 蓝色波纹管 Ø 23 mm, 长 3 m	Universal Robots / 优傲 机器人 UR 10	CLC0003
A A B C D	<b>BizLink B-Flex complete set UR 5 - Ø 23</b> 5x hook and loop fasteners 30 x 360 mm 5x hook and loop fasteners 30 x 460 mm 5x round holders 1x holder axis 6 with wrist support Ø 63 mm 1x corrugated hose Ø 23 mm blue, length 2 m	UR 5 - Ø 23 规格的整套 BizLink B-Flex 系统 5x 尼龙搭扣 (30 x 360 mm) 5x 尼龙搭扣 (30 x 460 mm) 5x 底座 1x 六轴带法兰支架 Ø 63 mm 1x 蓝色波纹管 Ø 23 mm, 长 2 m	Universal Robots / 优傲 机器人 UR 5	CLC0004
A B C D	<b>BizLink B-Flex complete set UR 3 - Ø 23</b> 5x hook and loop fasteners 30 x 360 mm 3x round holders 1x holder axis 6 with wrist support Ø 63 mm 1x corrugated hose Ø 23 mm blue, length 1.5 m	UR 3 - Ø 23 规格的整套 BizLink B-Flex 系统 5x 尼龙搭扣 (30 x 360 mm) 3x 底座 1x 六轴带法兰支架 Ø 63 mm 1x 蓝色波纹管 Ø 23 mm, 长 1.5 m	Universal Robots / 优傲 机器人 UR 3	CLC0005
A A B C D	<b>BizLink B-Flex complete set KUKA IIWA 14 R820 - Ø 23</b> 5x hook and loop fasteners 30 x 360 mm 5x hook and loop fasteners 30 x 460 mm 5x round holders 1x holder axis 6 with wrist support Ø 63 mm 1x corrugated hose Ø 23 mm blue, length 2.5 m	KUKA IIWA 14 R820 - Ø 23 规格的整套 Biz-Link B-Flex 系统 5x 尼龙搭扣 (30 x 360 mm) 5x 尼龙搭扣 (30 x 460 mm) 5x 底座 1x 六轴带法兰支架 Ø 63 mm 1x 蓝色波纹管 Ø 23, 长 2.5 m	KUKA / IIWA	CLC0006



## Connectors & contacts for spot welding / 点焊连接器与端子



Pos.	Description 描述	Axis	Type of assembly 平面安装	Article no. 订购号
1	BizLink connector for spot welding – compatible to MC RobiFix BizLink 点焊连接器, 适配 MC RobiFix	A1	Flat mounting 平面安装	CSW0001
2		A1		CSW0002
3		A1	Flange mounting 过板安装	CSW0003
4		A1		CSW0004



Pos.	Description 描述	Axis	Type of assembly 平面安装	Article no. 订购号
1	BizLink connector for spot welding – compatible to MC RobiFix BizLink 点焊连接器, 适配 MC RobiFix	A3	Flat mounting 平面安装	CSW0005
2		A3		CSW0006
3		A6		CSW0007
4	Socket contact / 母端子	A6		CSW0008
5	Socket contact / 母端子 8/35			CSW0009
6	Pin contact / 公端子 8/25			CSW0010
7	Pin contact / 公端子			CSW0011

## Special components & tools 特种零件与工具



Pos.	Description 描述	Material 材质	Article no. 订购号
1, 2	BizLink connector for feed-hose BizLink 送料管对接头	AL	CSP0001

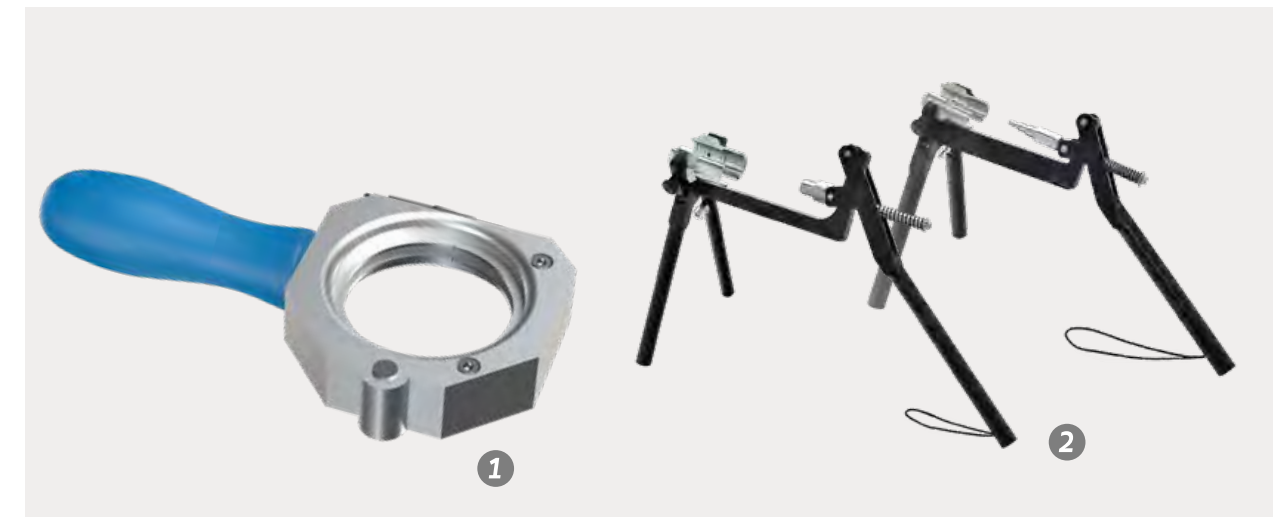

Pos.	Description 描述		Article no. 订购号
1	Cutting knife, for crosscutting corrugated hoses 切割刀, 用于横切波纹管	Ø 48 mm	CSP0002
		Ø 70 mm	CSP0003
2	Hose fitting insertion tool 软管接头压接工具		CSP0004

Connectors & contacts for spot welding  
Socket contact 8/25  
用于点焊的连接器和端子  
插座端子8/25

## Integration-ready robots 集成的机器人

We provide "Integration-Ready-Robots" including e.g. the robot dress, optimized dress packages, installed tools, installed process controllers, dense packs, electrical junction boxes etc. Amongst others we configure, set-up and test welding guns, software and Tool Center Point and also take care of the logistics.

### Your advantage > one-stop

我们提供“集成机器人”，包括机器人管线包、管线包优化、安装工具、安装程序控制器、电接线盒连线、整合包装等。除此之外，我们配置、装配和测试焊枪、软件和工具中心点，同时提供物流服务。

### 您的优势 > 一站式服务



GB



CN

The path from developing processes to starting production is a long one, and is characterised by many points of interface between production and business systems. Once we have done our work and the function package is ready, all that is left for you to do is plug in and produce.

#### And this is how we operate >

We plan for you and select only the best components. All the systems we design are assembled, set up and configured to your requirements. We take care of all coordination of components involved in the process, including the robot, and ensure that the corresponding programming, robot and tool calibration is in place. The brand of the robot – that you provide us with – does not matter.

When all tests have been faultlessly completed, the system is packed securely for transport and delivered to the set-up location. It is your choice where we assemble the system, either at our BizLink facilities, at your line builder or on-site. Thereafter, we will take care along with you of the final coordination and integration into the production process. We will familiarise your staff thoroughly with the system and, in the shortest possible amount of time, your robot will be welding its first spots, carrying out the handling and assembly tasks or commence calibrating or gluing. We provide first-class support after production has successfully started as well: We train your employees, maintain the equipment and replace wear parts in a timely manner. This minimises production downtime and saves a lot of expense. And should a problem arise nevertheless, our customers have a prompt repair service at their disposal.

- Large robot storage capability
- 48h notice on applications
- Professional logistic management system: 24h turn around (truck in / truck out)

从开发程序到投产的过程需要很长时间，需要定义生产和业务系统之间的很多接口点。一旦我们工作完成且功能包就位，您只需要接通电源就可以进行生产。

#### 我们这样做 >

我们为您制定好计划，并且选择最好的部件。我们设计的所有系统均按照您的要求组装、装配和配置。我们设计的所有系统均按照您的要求组装、装配和配置。安装过程中，我们注意协调各部件，包括机器人，保证相应的程序、机器人以及工具校准恰当。我们可以服务您提供的所有机器人品牌。

当无故障地完成所有测试后，打包管线包，运输交付至装配地点。您可以选择组装系统的地点：可以在我方的贸联工厂安装，也可以在您的系统集成商处或现场安装。其后，我们将和您共同负责最终协调并整合至生产流程中。我们将尽快使您的员工熟悉系统，并尽量在最短的时间内，将您的机器人整合到第一现场，执行装卸和安装任务，或校准或涂胶。顺利投产后，我们提供一流的支持：我们对顾客员工进行培训，包括设备维修并且及时更换磨损部件。如此一来，生产线的故障时间将降到最低，从而节省一大笔费用。万一发生故障，我们的顾客可获得快速相应的维修服务。

- 较大的机器人存储能力
- 48 小时相应
- 专业的物流管理系统：24小时周转（卡车装卸）



BizLink provides well-founded advice > supplies first-class single components > installs > takes over the setup > provides a dependable maintenance and repair service. Yet our real strength lies in the system solution. Only if everything matches, the optimum is reached. **Please contact us, we will be glad to make an offer.**

贸联提供充分的建议> 提供一流的单个组件>安装>负责设置>提供可靠的维修和修理服务。但是，我们真正的优势在于系统解决方案。只有所有部分匹配，才能实现最优。**请与我们联系，我们很乐意为您服务。**



# Function Packages > Integration-Ready Robots 功能包 > 集成的机器人

## Without BizLink / 无 BizLink

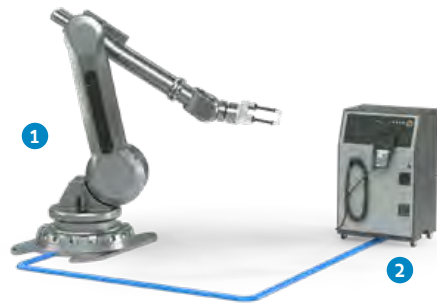

- 1 Robot / 机器人
- 2 Robot controller / 机器人控制器

## With / 含 BizLink

Integration-ready robots = BizLink function packages  
集成的机器人 = BizLink 功能包

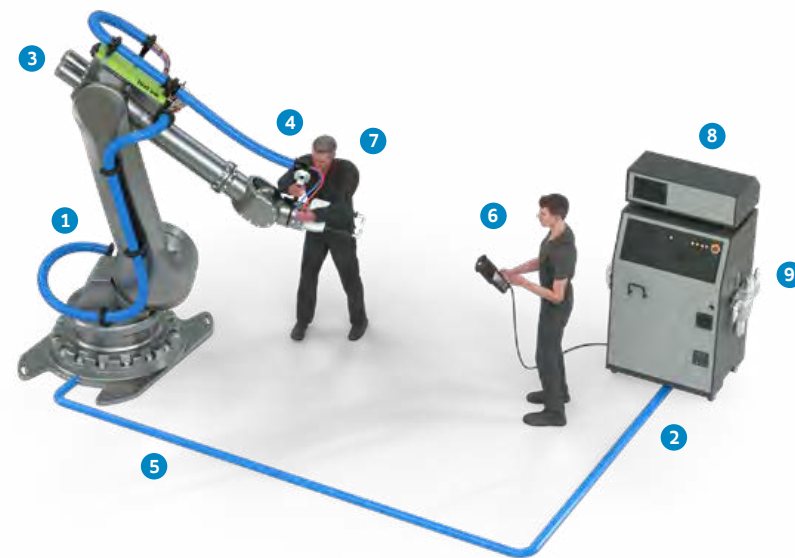

- 1 Robot / 机器人
- 2 Robot controller / 机器人控制器
- 3 Robot dresspack / 机器人管线包
- 4 Robot end of arm tooling / 机器人手臂末端工具
- 5 Power and media supply / 电力和通讯
- 6 Programming service / 编程服务
- 7 Installation and setup service / 安装和设置服务
- 8 PLC/HMI controller / PLC/HMI 控制器
- 9 Media panel / 媒体面板

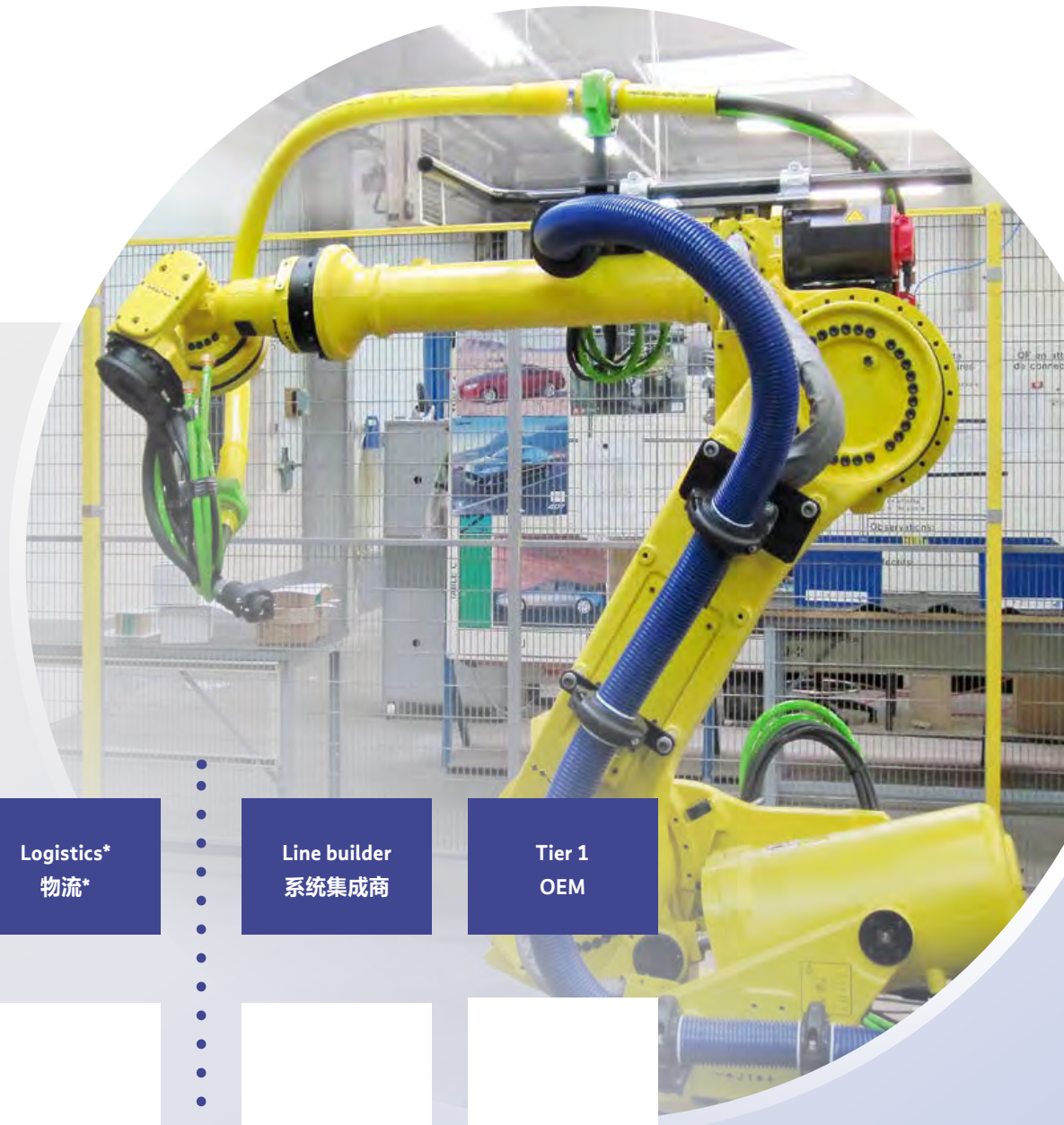

Logistics\*  
物流\*

Line builder  
系统集成商

Tier 1  
OEM

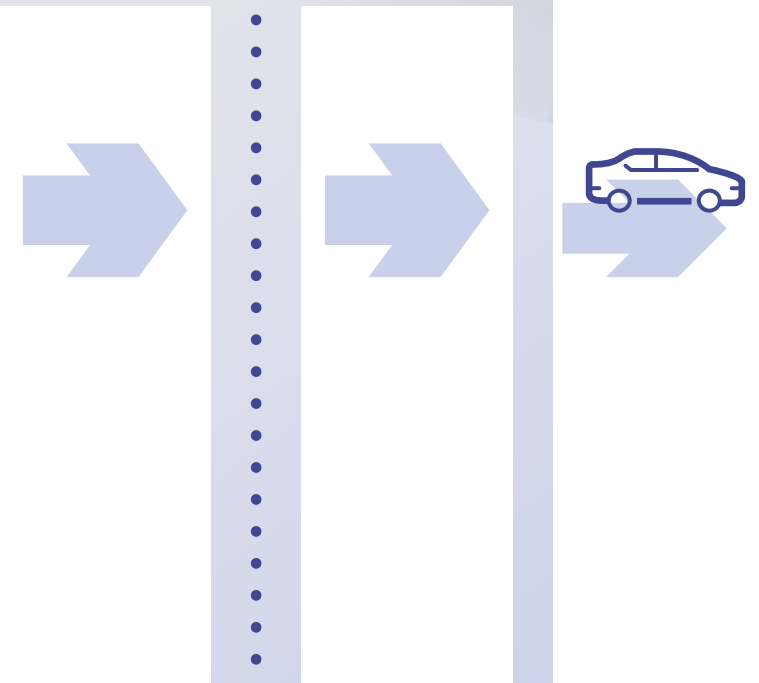

\* Possible scope of supply of BizLink / 贸联可供货范围



## Scope of Supply 供货范围

		Design 设计	Install 安装	Provide 供货	Service 服务
Receive Naked Robot	收到机器人裸机				
• Check Robot Configurations & Options	• 检查机器人配置和选项				X
• Flexibility to Change Configuration per Customer Request	• 根据客户要求更改配置			X	X
<b>Dresspack</b>	<b>管线包</b>	<b>X</b>	<b>X</b>	<b>X</b>	<b>X</b>
Robot Controller	机器人控制柜				
• Safety Interface	• 安全接口	X	X	X	X
Power and Media Supply	电力和通讯				
• I/O Cables	• I/O 电缆	X	X	X	X
• Communication Cables	• 通讯电缆	X	X	X	X
Programing Services	编程服务				
• PLC	• PLC		X		X
• Core and Customization Software	• 核心和客定软件		X		X
• Communication Mapping	• 通信映射		X		X
Installation and set up Services	安装和设置服务				
• Optimize Dress Pack	• 管线包优化			X	X
• Mount EOAT	• 安装 EOAT		X		
• Tune Gun	• 调较枪		X		X
• Tool Payload	• 工具有效负载		X		
• Calibrate Gun Pressure	• 校准喷枪压力		X		X
Application Power	应用电源				
• Signal & Communication Cables	• 信号与通信电缆	X	X	X	X
• Power Cables	• 电源线	X	X	X	X
• Mount Controller	• 安装控制器		X	X	X
• Special Hose or Tube	• 特殊软管	X	X	X	X
Media Panel	媒体面板				
• Air	• 空气	X	X	X	X
• Air and Water	• 空气与水	X	X	X	X
Additional Products & Services	额外的产品与服务				
• Robot Programmers	• 机器人编程			X	X
• Vision Integration	• 视觉集成	X	X	X	X
• Robot and PLC Training	• 机器人和PLC 培训	X		X	X

BizLink creates the Function Packages based on customer's request and specification for applications such as spot welding, inert gas welding, measuring, handling, and others. BizLink co-operates and supports integrators and line builders complying with your individual requests.

贸联根据客户要求和应用说明书 (例如, 点焊、惰性气体焊接、测量、处理以及其他措施) 来创建功能包。根据您的意愿, 贸联将配合和支持您的规划人员和系统集成商。

## Dresspack services 管线包服务

In addition to our existing broad product portfolio we support you with an extensive integrated industrial service range, worldwide – on site.

- › Installation
- › Optimization of dresspack systems and trajectories
- › Final check
- › Maintenance "management" service
- › Repair and refurbishment of dresspack systems

除了我们现有的广泛的产品组合外, 我们也在全球范围内提供广泛的现场综合工业服务。

- › 安装
- › 管线包系统和轨迹的优化
- › 最终检查
- › 维护管理服务
- › 管线包系统的维修和翻新



## Installation 安装

Starting with cable production through the installation, optimization and final check of the dresspack systems BizLink can reduce your downtime. We also offer after sales services such as preventive maintenance, repair and refurbishment of dresspacks or according trainings.

从电缆制造和水气管制造开始, 后续通过管线包的集成, 最后通过管线包的安装、优化以及最终检查, 我们最大程度减少您的故障停工时间。我们同样提供售后服务, 包括管线包的预防性维修、修理以及翻新。

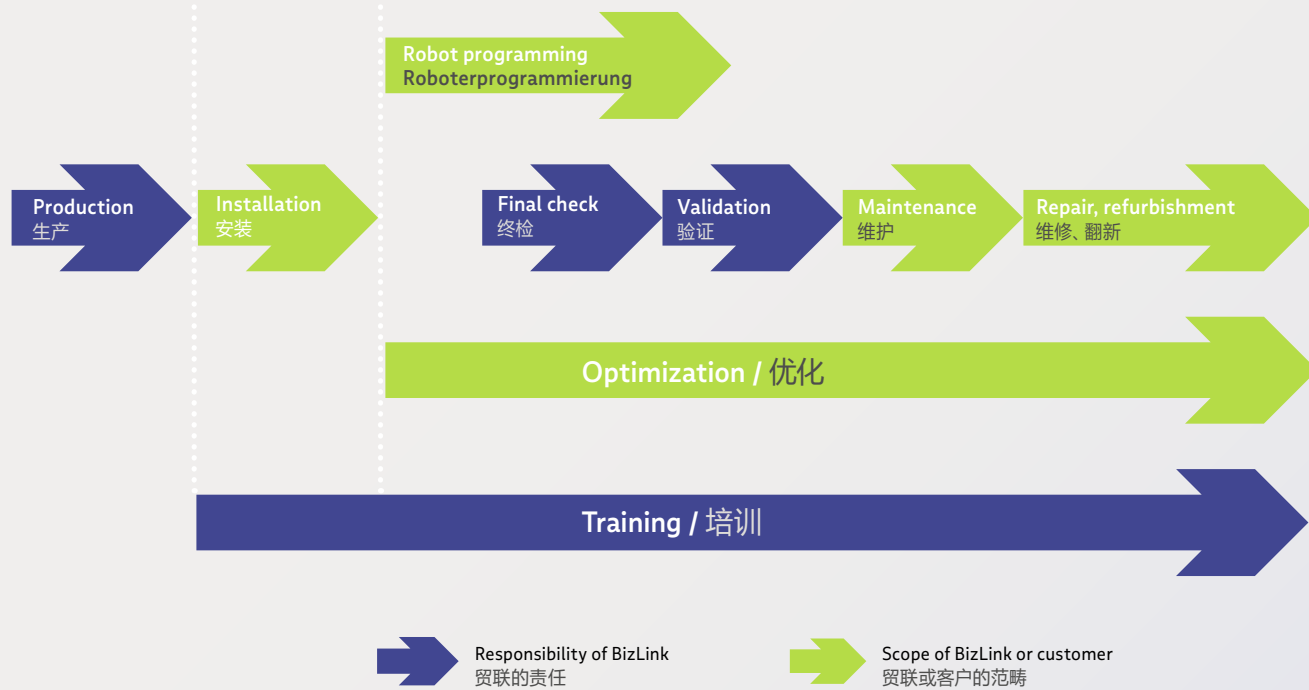

BizLink recognizes the importance of providing professional installation services to secure a smooth operating schedule for the customer.

对贸联而言, 提供专业的安装服务对确保可靠稳定的生产十分重要。

Our globally experienced service teams make sure that BizLink dresspack systems are installed, professionally. Quickly, on-site, worldwide.

我们经验丰富的全球服务团队, 确保贸联管线包可以在全球范围内得到专业安装。服务覆盖全球、现场进行、快速高效。

## Optimization of dresspack systems and trajectories\* 管线包与轨迹优化\*

The optimization of dresspack systems goes hand in hand with robot programming. Only perfectly coordinated robot movements and the corresponding positioning of the dresspack ensure a maximum lifetime of the total system – you can rely on us.

管线包的系统优化与机器人编程密切相关。只有当机器人完美协调地运作, 同时与管线包的优化定位, 确保整个系统的寿命达到最长——完美值得您的信赖。

BizLink offers you one-stop robot programming and optimization and during the whole lifecycle of your system. If you decide on robot programming being conducted by your own staff we support and advise them on site.

贸联为您提供一站式终身机器人编程和优化服务。如果您决定由您自己的员工进行机器人编程, 我们将会提供现场支持与意见。

The optimization includes among others

- Optimization of the interference-free trajectory
- Adjustment of the ideal length of the tool components at junction 6 and of the interface at junction 3
- Improving position and relocation of support parts
- Test protocol of the optimization including pictures

优化服务包括以下内容:

- 免干扰轨迹优化
- 调整6轴组件以及3轴处接口的理想长度
- 改进支撑部分位置, 纠正错位现象
- 包括图像在内的优化记录

Our warranty extends to newly installed spare parts only. In particular critical applications can require extraordinary solutions. In such ones we are happy to offer you application-specific mounting and guiding systems.

缺陷责任范围仅适用于新近安装的备件。针对特殊关键应用, 我们可以提供特殊的解决方案。我们还将单独为您提供特定应用的安装指导书。



\* Project specific differences regarding the scope of work are possible

\*可能存在工作范围的具体项目差异。

## Final Check\* 最终检查\*



A final check is required to establish the basis for BizLink's warranty / product liability (country-specific).

为明确落实缺陷责任的法律范围 (各国情况存在差异), 必须进行最终检查。

With this additional service we confirm the installation as compliant to the customers' specifications and its suitability for serial production.

通过这些服务, 我们确认您的系统按照标准运转, 符合制定轨迹的位置和路线。

The final check includes among others

- Improving position and relocation of support parts if necessary
- Adjustment of the ideal length of the components at junction 6 and of the interface at junction 3

最终检查包括以下内容:

- 改进支撑部分位置, 纠正错位现象
- 调整6轴组件以及3轴处接口的理想长度

If the system is found to be damaged or if further optimization appears necessary (e. g. special support parts) we provide a list of these changes with a view to ensuring the maximum service life of the system.

如果系统遭到破坏, 或者需要进一步优化 (例如: 尤其是支撑部分), 为保证您所用系统的理想寿命, 我们会向您发出一张清单, 列出需要进行的调整。

In any event and subject to customer approval a copy of the robot program at the time is documented. To complete the test record photo documentation of the final check can be provided. BizLink conducts this final check worldwide, on-site.

未来保护您的切身利益, 经您允许后, 我们将保存机器人程序的最新版本。我们可以为客户提供最终检查的图像文件以及测试记录。我们可在全球范围内进行现场最终检查。

\* Project specific differences regarding the scope of work are possible

\* 可能存在工作范围的具体项目差异。

## Maintenance "management" service\* 维修“管理”服务\*



This service from BizLink further increases your plant uptime.

贸联的这项服务进一步延长了您工厂的正常运行时长。

BizLink provides you specialised dresspack maintenance support.

贸联为您提供专业的管线包维修支持。

This includes the analysis of failure-modes based on long-term observation as well as system audits (target-performance comparison of e. g. TPM measures) with resultant performance improvement to the customer. It also implies the creation of maintenance guidelines.

包括长期对故障模型的认识和系统分析 (例如TPM测量下目标性能比较), 从而提升整体性能。它同样包含制定维修指南。

### Our BizLink service technician performs routine maintenance visits >

- He always carries out this maintenance with the help of innovative, computer-aided maintenance management tools.
- He provides ongoing support at your plant and can thus point out optimization potential or wear at an early stage.
- He advises you on the selection of the right spare parts and thus ensures timely replacement before costly production stoppages occur.
- With additional tips for immediate measures, he supports your own maintenance.
- Flexibility and a broad know-how also for special applications characterize our BizLink service technician.

### 我们的技术服务人员进行日常维护访问 >

- 总在创新的计算机辅助维护管理工具的帮助下进行维护。
- 为您的工厂提供持续的支持, 因此可在早期阶段指出优化潜力或磨损。
- 建议您选择正确的备件, 从而确保在发生代价高昂的停产前及时更换备件。
- 给予立即行动的小贴士, 支持您自主维护。
- 我们的技术服务人员遇事灵活, 且拥有广泛的针对特殊应用的专业知识。

\* Project specific differences regarding the scope of work are possible

\* 可能存在工作范围的具体项目差异。



## Repair and refurbishment of dresspack systems\* 管线包系统的维修与翻新\*

We secure fast and effective help in the event of a breakdown >

- We exchange broken parts.
- Reuse of functional components to rebuild and re-integrate into new systems.
- Refurbishment, i.e. dismantling and proper disposal of the old system.
- Installation of a new system considering state of the art technique is taken care of by us.
- This results in direct cost savings for you.

发生故障时, 我们确保提供快速有效的帮助 >

- 更换损坏的零件。
- 重复使用功能配件来重建并集成到新系统中。
- 翻新, 即拆除并妥善处理旧系统。
- 安装使用最新技术的系统。
- 这为您直接节省成本。

## Training / Schulung



### Service life is influenced by a number of factors >

It is directly affected not only by the quality of the components but also by the skills of the local service technician. Our specialised team of technical coaches works to ensure 100% knowledge transfer and offers on-site training courses for your personnel to ensure that they can carry out repairs, changes and replacements for dresspack components both independently and to a professional standard.

\* Project specific differences regarding the scope of work are possible

### 使用寿命受多重因素影响 >

它不仅受到零部件质量的直接影响, 还受当地服务技术人员技能的直接影响。我们的专业技术教练团队致力于确保100%的知识传授, 并为您的人员提供现场培训课程, 以确保他们能按照专业标准独立对管线包组件进行维修、更改和更换。

\* 可能存在工作范围的具体项目差异。

## Conversion tables / 换算表

Conversion inch – centimeter / 英寸换算为厘米		
1 inch / 英寸	=	2.54 cm
2 inch / 英寸	=	5.08 cm
3 inch / 英寸	=	7.62 cm
4 inch / 英寸	=	10.16 cm
5 inch / 英寸	=	12.70 cm
6 inch / 英寸	=	15.24 cm
7 inch / 英寸	=	17.78 cm
8 inch / 英寸	=	20.32 cm
9 inch / 英寸	=	22.86 cm
10 inch / 英寸	=	25.40 cm
20 inch / 英寸	=	50.80 cm
30 inch / 英寸	=	76.20 cm
40 inch / 英寸	=	101.60 cm
50 inch / 英寸	=	127.00 cm
60 inch / 英寸	=	152.40 cm
70 inch / 英寸	=	177.80 cm
80 inch / 英寸	=	203.20 cm
90 inch / 英寸	=	228.60 cm
100 inch / 英寸	=	254.00 cm
1000 inch / 英寸	=	2540.00 cm

Conversion centimeter – inch / 厘米换算为英寸		
1 cm	=	0.3937 inch / 英寸
2 cm	=	0.7874 inch / 英寸
3 cm	=	1.1811 inch / 英寸
4 cm	=	1.5748 inch / 英寸
5 cm	=	1.9685 inch / 英寸
6 cm	=	2.3622 inch / 英寸
7 cm	=	2.7559 inch / 英寸
8 cm	=	3.1496 inch / 英寸
9 cm	=	3.5433 inch / 英寸
10 cm	=	3.9370 inch / 英寸
20 cm	=	7.8740 inch / 英寸
30 cm	=	11.8110 inch / 英寸
40 cm	=	15.7480 inch / 英寸
50 cm	=	19.6850 inch / 英寸
60 cm	=	23.6220 inch / 英寸
70 cm	=	27.5591 inch / 英寸
80 cm	=	31.4961 inch / 英寸
90 cm	=	35.4331 inch / 英寸
100 cm	=	39.3701 inch / 英寸
1000 cm	=	393.7008 inch / 英寸

Conversion Fahrenheit to Celsius / 华氏温度换算为°C			
Conversion Celsius to Fahrenheit / °C换算为华氏温度			
°C	F	°C	F
-18	0	1	34
-17	1	2	36
-16	3	3	37
-15	5	4	39
-14	7	5	41
-13	9	6	43
-12	10	7	45
-11	12	8	46
-10	14	9	48
-9	16	10	50
-8	18	11	52
-7	19	12	54
-6	21	13	55
-5	23	14	57
-4	25	15	59
-3	27	16	61
-2	28	17	63
-1	30	18	64
0	32	19	66

F – 32 * 5 / 9 = C			
(°C * 9 / 5) + 32 = F			
°C	F	°C	F
20	68	39	102
21	70	40	104
22	72	41	106
23	73	42	108
24	75	43	109
25	77	44	111
26	79	45	113
27	81	46	115
28	82	47	117
29	84	48	118
30	86	49	120
31	88	50	122
32	90	51	124
33	91	52	126
34	93	53	127
35	95	54	129
36	97	55	131
37	99	56	133
38	100	57	135



# 工厂自动化

## Our market segment in all its diversity

With innovative solutions for intelligent energy and data management in automated production processes, BizLink has been for years a preferred supplier of many automotive and factory automation OEMs.

BizLink products are already facing up to the key future trend of digitalisation with an extensive and innovative range of complementary products and services in the market segments Automation, Drives and Robotics.

In several competence centres around the world BizLink develops and produces bus cables, Industrial Ethernet and Motion Control cables as well as cable systems and services. Connector development and production as well as assembled drag chains round off the product portfolio. Moreover, BizLink supplies a wide variety of solutions, including robotic cables and their assembly, hoses and tubes, dresspack systems, integration-ready robots, robot programming and automation systems training. In view of the increasing digitalization BizLink provides integrated and intelligent sensor-based measuring solutions. BizLink markets this product variety via a global sales organisation at nearly 50 locations.

Their sharp focus on service and increasing product diversification provides impetus for developing these markets further. With its product range BizLink confronts the market's challenges by way of ongoing collaboration with technology leaders and user organisations, and it actively develops products as well as services to meet the trends of the future, especially with respect to the increasing digitalisation.

**Thus, BizLink is taking an important step towards meeting future market requirements in a 'smart' way.**

## 我们多元化的细分市场

BizLink 贸联致力于为自动化生产过程提供智慧能源与数据管理的创新解型决方案, 多年来深受众多汽车及工厂自动化 OEM 厂商信赖。

BizLink 贸联积极面对数字化的未来, 为自动化、驱动技术和机器人领域提供广泛且创新的配套产品和服务。

在全球的多个技术中心, BizLink 贸联研发并生产总线电缆、工业以太网电缆和运动控制电缆以及电缆系统和服务。连接器的研发与生产以及拖链的预装配均围绕此产品组合展开。此外, BizLink 贸联可提供一系列解决方案, 包括机器人电缆以及相关组件、水管、气管和软管、管线包系统、机器人预集成、机器人编程和自动化系统培训。随着数字化的不断发展, BizLink 贸联提供集成了传感器的智能测量解决方案, 并通过近 50 处的销售网络服务全球市场。

对服务的高度重视和增加产品多样性是促进市场进一步发展的动力。依靠丰富的产品系列, BizLink 贸联与技术领导者和用户组织持续合作, 共同应对市场挑战。面对未来数字化的持续发展, BizLink 贸联积极研发产品及服务。

**因此, BizLink 贸联正在以“智能”的方式朝着满足未来市场需求迈出重要的一步。**

Find out more | 了解更多 >

[factory-automation.bizlinktech.com](http://factory-automation.bizlinktech.com)



## About BizLink Group

## 关于 BizLink 贸联

# BizLink

Find out more | 了解更多 >  
[www.bizlinktech.com](http://www.bizlinktech.com)

**BizLink, founded in 1996, is headquartered in Fremont, in the heart of the Silicon Valley, USA. Our mission is to make interconnection easier and to become the leading global interconnect solution supplier.**

We support industries that are environmentally conscious and improve quality of life through providing essential components, wire harnesses, and cables to a wide variety of industries such as IT Infrastructure, Client Peripherals, Optical Fiber Communications, Telecom and Networking, Electrical Appliances, Healthcare, Factory Automation, Machinery and Sensors, Motor Vehicle, Rolling Stock, Marine, Industrial, and Solar.

In addition, with flexible production resources and global R&D teams in America, Europe, and Asia, BizLink always provides reliable interconnect solutions in close proximity to markets. BizLink also specializes in providing one-stop EMS and NPI services based on customer's requests.

At BizLink, we strive to keep collaborating closely with customers to turn their innovative ideas into reality.

**BizLink 贸联成立于 1996 年，总部位于美国硅谷。我们的使命是让互联更容易，成为全球领先的互联解决方案供应商。**

我们通过为 IT 基础设施、客户端外围设备、光纤通信、电信和网络、电器、医疗、工厂自动化、机械与传感、机动车辆、轨道交通、海事、工业和太阳能等各种行业提供必要的组件、线束和电缆来支持具有环保意识并提高生活质量的行业。

此外，凭借灵活移动的生产资源和遍布美洲、欧洲和亚洲的全球研发团队，BizLink 贸联始终提供贴近市场的可靠互联解决方案。BizLink 贸联还专门根据客户的要求提供一站式 EMS 和 NPI 服务。

BizLink 贸联努力与客户保持密切合作，将其创新想法变为现实。

Interconnect Made Easy.

# Sales network / 销售网络

# Your contact / 联系我们

## BizLink Robotic Solutions 机器人解决方案

**BizLink Robotic Solutions**  
Competence centers / 能力中心



**BizLink Robotic Solutions Germany GmbH**  
 Bruesseler Strasse 12  
 30539 Hanover  
 Germany  
 T +49 511 12 35 76-30

An der Auehuetten 10  
 98574 Schmalkalden  
 Germany  
 T +49 3683 6505-0

**贸联特种电缆(常州)有限公司**  
 江苏省常州市新北区  
 太湖西路21号 213022  
 T +86 519 89887105

**BizLink Robotic Solutions France S.A.S.**  
 1, Avenue Louis Pasteur / ZI de Gellainville  
 28630 Gellainville  
 France  
 T +33 2373375-00

**BizLink Robotic Solutions USA, Inc.**  
 100 Kay Industrial Drive  
 Lake Orion, Michigan 48359-1831, USA  
 T +1 248 484-5500

5211 Linbar Drive, Suite 505  
 37211 Nashville, TN, USA  
 T +1 615 540-1533



## 工厂自动化

### 贸联特种电缆(常州)有限公司

工厂地址:

江苏省常州市新北区太湖西路21号

电话: 0519-8988 7105

上海办事处:

上海市长宁区遵义路107号安泰大楼605室

电话: 021-6237 5569 ext. 101

邮箱: bcn\_robotics@bizlinktech.com

### BizLink Robotic Solutions Germany GmbH

Brüsseler Strasse 12 · 30539 Hannover

Germany



[factory-automation.bizlinktech.com](https://factory-automation.bizlinktech.com)

[in](#) Follow us on LinkedIn

[B](#) Access web shop

© 2023 BizLink Group. All rights reserved. August 2023  
BizLink and other trademarks are trademarks of BizLink Group or its subsidiaries.  
Other trademarks may be trademarks of their respective owners.  
Specifications are subject to change without prior notice.